



PROFESSIONAL

TX6600PRO

5 WATT IP67 UHF PRO CB HANDHELD RADIO



INSTRUCTION MANUAL

CONTENTS

PREFACE	1
COPYRIGHT NOTICE	1
SAFETY INFORMATION	1
IMPORTANT INFORMATION CONCERNING UHF CB RADIO	1
EMERGENCY CHANNELS	2
TELEMETRY CHANNELS	2
IMPORTANT ADVICE	3
INTRODUCTION	4
ACCESSORIES SUPPLIED	4
TX6600PRO	4
FEATURES	5
TRANSMIT (TX)	5
RECEIVE (RX)	5
SCANNING AND MEMORY FUNCTIONS	5
PRIVACY FUNCTIONS	6
PHYSICAL PROPERTIES	6
USER CONTROLS AND INTERFACE	6
SIGNAL PROCESSING	6
CONTROLS	8
DISPLAY	9
GETTING STARTED	9
FITTING THE BATTERY	9
REMOVING THE BATTERY	9
CHARGING THE BATTERY	10
BATTERY LOW ALERT	11
BELT CLIP	12

GENERAL OPERATION	12
OPERATION OF THE KEYS	12
ON/OFF AND VOLUME	13
SELECTING CHANNELS	13
TRANSMITTING	13
RECEIVING	14
SIGNAL STRENGTH METER	14
SQUELCH	15
SQUELCH LEVEL	16
PRIORITY CHANNEL	17
DUAL WATCH	18
TRIPLE WATCH	18
SCAN GROUPS	19
DUPLEX	20
PRO KEY	21
PRO KEY ASSIGNMENTS	22
LOCK KEY	22
TRANSMIT POWER	23
BUSY LOCKOUT	23
TIME-OUT TIMER	24
ROGER BEEP	24
MICROPHONE GAIN	25
VOICE SCRAMBLER	25
NARROW BAND FILTER	26
SILENT SQUELCH TAIL	27
DYNAMIC VOLUME CONTROL	27
LCD BACKLIGHT	28
BEEPS	29
CHANNEL ANNOUNCE	29

DISPLAY OPTIONS.....	30
MESSAGE TEXT.....	31
POWER SAVE.....	32
RADIO INFORMATION.....	32
FACTORY RESET.....	33
SCANNING	34
OVERVIEW	34
ADDING AND REMOVING SCAN CHANNELS.....	35
OPEN SCAN MODE.....	36
GROUP SCAN MODE	37
NETWORK SCAN MODE.....	39
CTCSS AND DCS	42
SELCALL.....	45
OVERVIEW	45
CALL MENU.....	46
RECEIVING A SELCALL	51
SCANNING IN QUIET MODE	54
GROUP CALLING	55
CONSERVING YOUR BATTERY POWER	56
MENU	57
PRIVATE AND RECEIVE-ONLY CHANNELS.....	58
PROGRAMMABLE KEYS	67
MENU OPTIONS	82
CTCSS TONE FREQUENCIES	83
DCS CODES	84
UHF CB OPERATING FREQUENCIES.....	85
SPECIFICATIONS.....	86
WARRANTY	88

COPYRIGHT NOTICE

GME Pty Ltd reserves all rights to this document and the information contained herein. Reproduction, use or disclosure to third parties without express permission is strictly prohibited.

© 2020 GME Pty Ltd, Sydney, Australia

SAFETY INFORMATION

The TX6600PRO is a radio transmitting device.

- When transmitting, keep the antenna more than 25 mm from any part of the head or body.
- Do not transmit near electrical blasting equipment or in explosive atmospheres.
- Do not allow children to operate a radio transmitter unsupervised.

IMPORTANT INFORMATION CONCERNING UHF CB RADIO

The use of the Citizen Band radio service is licensed in Australia by the ACMA Radio communications (Citizens Band Radio Stations) Class Licence and in New Zealand by the Ministry of Economic Development New Zealand (MED). A General User Radio Licence for Citizens Band radio and operation is subject to conditions contained in those licences. The class licence for users and equipment operating in the CB/PRS 477 MHz band has been amended. This radio meets the new 80 channel standard.

In simple terms the same amount of spectrum is available; however, radio transceivers can now operate in a narrower bandwidth and hence use less spectrum per channel. These radios are generally referred to as narrowband or 12.5 kHz radios. By using 12.5 kHz channel spacing instead of 25 kHz, the 40 channels originally allocated can now be expanded to 80 channels thereby doubling the channel capacity and relieving congestion in the UHF CB/PRS band.

Older 40 channel wideband radios will continue to operate on the original 40 channels, however they will not be able to converse on the newer channels 41 – 80. The newer narrowband radios will be able to converse with all older 40 channel wideband radios on all channels 1 – 40 as well as the newer channels allocated from 41 – 80.

The mixing of narrowband and wideband radios in the same spectrum may possibly cause operating issues of interference and varying levels of received volume. For example, when a new narrowband radio receives a transmission from an older wideband radio the speech may sound loud and distorted. Alternatively, when an older wideband radio receives a signal from a new narrowband radio, the speech may sound quiet. In each case, simply adjust your radio volume for best performance.

Depending on how close your receiving radio is to another transmitting radio, there might be interference from the transmitting radio if it is using a channel adjacent to the channel you are listening to. Simply switch up or down a few channels from the currently selected channel.

The above situations are not a fault of the radio but a symptom of operating wideband and narrowband radios in the same bandwidth. These minor issues should decrease over time as the population of wideband radios ages and decreases.

Further information and updates are available from the Australian Communications and Media Authority (ACMA) at www.acma.gov.au and the Ministry of Economic Development (MED), Radio Spectrum Management at www.rsm.govt.nz.

EMERGENCY CHANNELS

The ACMA has allocated channels 5/35 for emergency use only.

Channel 5 is the primary Simplex Emergency Channel. Where a channel 5 repeater is available, you should select Duplex on channel 5.

Channel 35 is the input channel for the channel 5 repeater. Therefore channel 35 should also not be used for anything other than emergency transmissions.

TELEMETRY CHANNELS

ACMA regulations have allocated channels 22 and 23 for telemetry-only applications and have prohibited the transmission of speech on these channels. Consequently the radio has a transmit inhibit applied to channels 22 and 23.

In the event that additional telemetry/telecommand channels are approved by the ACMA, these channels shall be added to those currently listed where voice transmission is inhibited. Currently, transmissions on channels 61, 62 and 63 are also inhibited and these channels are reserved for future allocation.

IMPORTANT ADVICE

- Read all instructions carefully and completely before operating your radio and retain this manual for future reference.
- **Never** connect the radio to a power source other than the supplied battery. This may damage your radio.
- **Do not** place your radio in front of a vehicle airbag.
- **Do not** use your radio with a damaged antenna.
- **Do not** attempt to modify your radio in any way.
- **Always** charge your radio at normal room temperature.
- **Always** switch off your radio where notices restrict the use of two-way radio or mobile telephones.
- **Use only** GME approved rechargeable battery packs with the supplied charger.
- **Avoid** storing or charging your radio in direct sunlight.
- **Avoid** storing or using your radio where temperatures are below -20°C or above +60°C.

INTRODUCTION

Your GME TX6600PRO 80 channel radio is Australian designed and manufactured and is the most advanced UHF Citizen Band radio available. GME has an extensive range of Handheld UHF CB Radios to meet a variety of needs. From 4WDing to construction sites, GME has a handheld to suit.

Our TX6600PRO features class-leading 5 Watt transmission power, an IP67 ingress-protection rating for outstanding performance and years of reliable use in the harshest Australian environments, multiple power saving modes, Scansuite™ digital scanning technology and channel selection with voice announcement.

Designed, engineered and manufactured in Australia, the TX6600PRO is ideal for users who demand the ultimate in handheld UHF CB communication, for both work and play.

ACCESSORIES SUPPLIED

TX6600PRO

- 5 Watt IP67 UHF PRO CB Handheld Radio (TX6600PRO)
- 2600 mAH Li-ion Battery Pack (BP028)
- Desktop Charger (BCD022)
- AC Adaptor (PS005)
- Removable Flexible Antenna (AE4028)
- Belt Clip (MB058)

FEATURES

TRANSMIT (TX)

- **5W/1W/100mW RF Power:** Selectable transmitter power allows you to conserve the battery when transmitting in close range by using the Low (1W) or Ultra-Low (100mW) Power setting.
- **Individually Programmable Duplex Function:** User selectable for only those individual channels in your area that have repeaters, leaving others free for use as extra simplex channels.

RECEIVE (RX)

- **CB Channels:** 80* channels 477 MHz UHF CB
- **Advanced Power Saving Feature:** Allows the TX6600PRO to 'sleep' during periods of inactivity to conserve battery power.
- **Digital Signal Strength Meter:** Displays the incoming signal strength in digital format.
- **Silent Squelch Tail:** Eliminates the squelch noise burst in the receiving radio.
- **User Programmable Channels:** 119

SCANNING AND MEMORY FUNCTIONS

- **Microprocessor Controlled Frequency Synthesiser:** Allows user programmable control of scanning, channel memories and selected feature options.
- **Programmable Scan Function:** Scans up to 80 UHF CB channels and up to 119 user programmable channels.
- **Dual Watch:** Scans two channels, working and priority.
- **Triple Watch:** Scans three channels, working and both priority.
- **Priority Channels:** Two separate Priority Channels allow any channels of your choice to be instantly recalled at the press of one of the Priority keys.

PRIVACY FUNCTIONS

- **Voice Inversion Scrambler:** A voice scrambler that, when activated, will make your transmission and reception intelligible only to other radios using the same scrambler technology.
- **CTCSS & DCS:** Built-in Continuous Tone Coded Squelch and Digital Coded Squelch systems provide silent channel operation.
- **In-Built SelCall with Quiet Mode:** Provides selective calling of individuals or groups with fully user-adjustable transmitted SelCall Ident. Includes a SelCall contact list containing up to 48 SelCall contacts with alphanumeric naming for easier caller identification.

PHYSICAL PROPERTIES

- **Water & Dust Proof IP67:** Provides protection against dust and temporary immersion in water.
- **Removable Antenna:** High performance flexible antenna included.
- **Heavy-duty Construction:** Rugged construction with Die-cast Chassis.
- **Battery Pack:** Heavy duty 7.4V 2600 mAh Li-ion.

USER CONTROLS AND INTERFACE

- **High Contrast Liquid Crystal Display:** Fully detailed LCD provides a visual indication of the channel and all selected features at a glance.
- **Keypad Lock:** Prevents accidental key presses from disrupting the normal operation of your radio.
- **LED Backlight:** For night viewing with automatic time-out.
- **Channel Announce:** An audible voice that speaks the channel number whenever a channel is selected.

SIGNAL PROCESSING

- **Digital Signal Processing (DSP):** Measures, filters and compresses standard analogue audio signals and converts them to digital format. Allows advanced digital audio processing techniques to be applied to maximise the radio's performance.

- **Advanced Signal Management (ASM):** Identifies interference caused by strong local signals on adjacent channels and prevents it from opening the squelch. ASM also minimises distortion on reception by fine tuning the receiver frequency to match that of the incoming signal. This prevents your squelch from opening to unwanted interference and ensures that incoming signals remain clear and undistorted even when they are slightly off-frequency.
- **Dynamic Volume Control:** Automatically compensates for variations in received audio level resulting in a constant audio output level to the speaker.

† Refer to the preface above for important information concerning the UHF CB radio.

CONTROLS

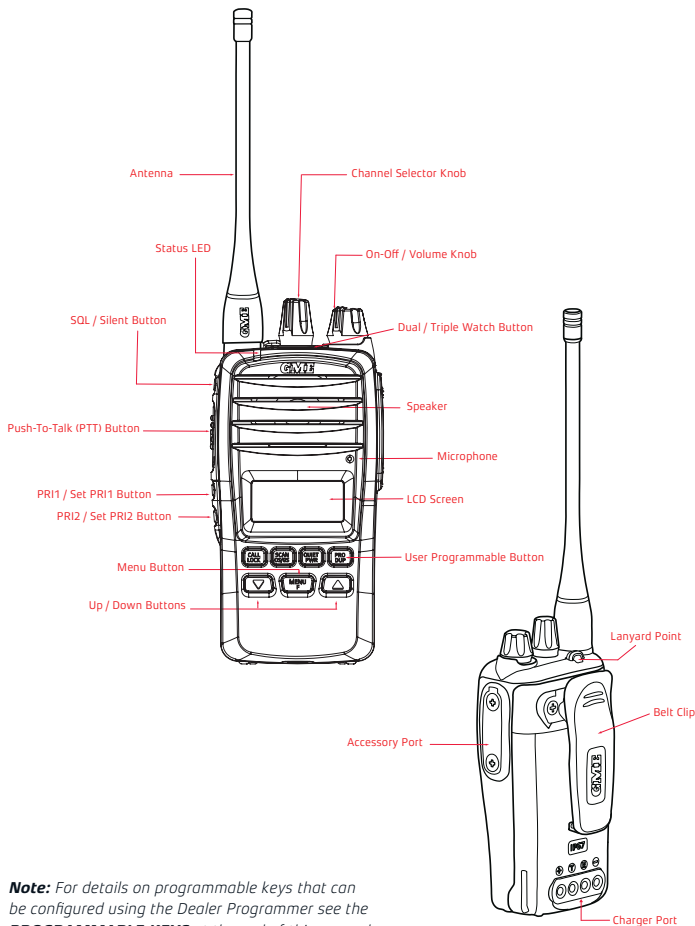

Note: For details on programmable keys that can be configured using the Dealer Programmer see the **PROGRAMMABLE KEYS** at the end of this manual.

DISPLAY

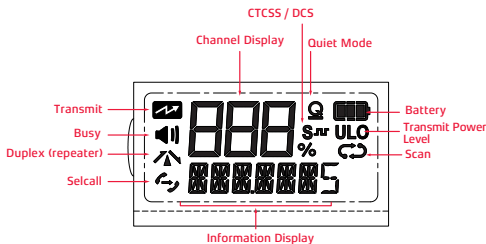

GETTING STARTED

Your TX6600PRO is supplied with a 7.4 Volt 2600 mAh Li-ion rechargeable battery pack. You should fully charge the battery before using it for the first time.

If left unused your radio's battery pack may slowly discharge over time. If you have not used your TX6600PRO for some time, you should recharge the battery pack before use.

The battery pack is a sealed unit. There are no user serviceable parts inside.

WARNING: Use only GME approved battery packs and chargers. Use of other types may be dangerous and will void the warranty.

FITTING THE BATTERY

1. Align the slots in the battery with the metal tabs on the radio chassis.
2. With the battery pressed against the radio, slide it upwards until it 'clicks'.

REMOVING THE BATTERY

1. Locate the battery latch on the base of the radio.
2. Pull the battery latch forward while sliding the battery downwards from the radio. Once the battery has been released, lift it away from the radio.

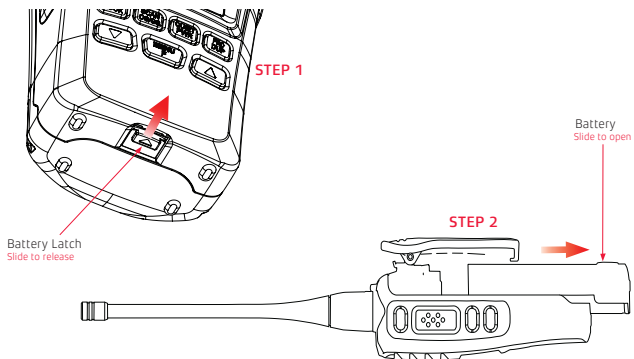

The desktop charger is designed to charge the battery while it is attached to the radio. Simply press the radio (with the battery attached) firmly into the charging slot so the contacts on the battery align with the contacts in the charger slot.

Alternatively, the battery can be removed and charged separately by inserting it into the slot at the rear of the desktop charger compartment.

CHARGING THE BATTERY

1. Plug the PS005 AC adaptor into a standard 240 Volt outlet.
2. Plug the lead from the PS005 into the charging socket on the rear of the BCD022 charging cradle.
3. Place the TX6600PRO with battery attached into the charging slot. The charger indicator LED will light Red.
4. Once the battery is charged, the charger indicator LED will change to Green.

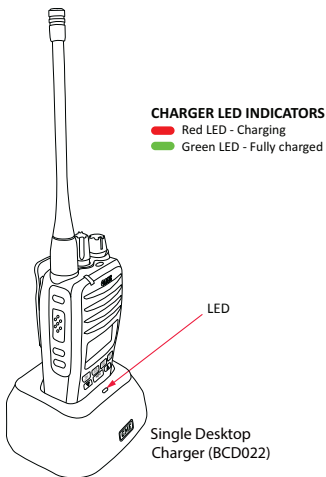

BATTERY LOW ALERT

As the battery voltage is depleted the internal segments of the battery icon will extinguish one by one. When the last segment is extinguished the remaining battery outline will flash to indicate the battery level is low. You should recharge the battery as soon as possible. If you continue using your radio when the battery indicator is flashing it will operate with Ultra-Low transmit power until the battery is depleted.



Full



Medium



Low



Recharge

BELT CLIP

To attach the belt clip:

1. Position the clip on the rear of the radio.
2. Attach using the screws supplied.

GENERAL OPERATION



Please refer to the diagrams on the 'Controls' page for a general description of the controls and keys.

OPERATION OF THE KEYS

Where the instruction says **Press** you should briefly press and release the key to activate its feature. Where the instruction says **Hold** you should press and hold the key for about 2 seconds to activate its feature.

Key Beeps

If the BEEP option in your radio's menu is enabled, a beep will be heard whenever a key is pressed. A high beep indicates the key's function has been activated successfully. A rising two-tone beep indicates a function has been switched On while a falling two-tone beep indicates the function has been switched Off. A falling two-tone beep will also be heard when a key's function cannot be selected.

NOTE: If Channel Announce is switched On, beeps will not be heard when rotating the **Channel** knob or pressing the   keys. Instead, a voice will be heard announcing the channel.

Function Key

Most keys have multiple functions that are printed on the key in white and red.

The primary key functions are printed in white. There are usually two operations related to each primary function and these can be accessed either by briefly pressing the key or by holding the key.

To access the secondary functions printed in Red you need to first press the  key. 'F' will be displayed to indicate you are in Function mode. While 'F' is displayed, press the desired Red key within 10 seconds to activate that function.



ON/OFF AND VOLUME

Rotate the **Volume** Knob clockwise past the 'click' to switch the radio on. Continue to rotate the **Volume** Knob clockwise to increase the volume.

Rotate the **Volume** Knob counter-clockwise to decrease the volume. Continue to rotate the **Volume** Knob counter-clockwise past the 'click' to switch the radio off.

NOTE: If there are no signals available when adjusting the volume, set the **Volume** knob to the 10 o'clock position. This should ensure sufficient volume to hear incoming signals when they occur.

SELECTING CHANNELS

To select a channel, rotate the **Channel** knob or press the   keys. The selected channel will be shown on the display. If Channel Announce is On, the channel number will be announced.

TRANSMITTING

Before transmitting, check to see if the channel is already in use (the  icon will be visible). If the channel is busy, you should wait until it is clear before transmitting.

NOTE: If the **Busy Lockout** feature is enabled in your radio's menu, your radio will automatically prevent you from transmitting while the channel is busy.

To transmit:

1. Press and hold the **PTT** (Push-to-Talk) key.
2. Hold the radio 3-5cm from your mouth and speak into the microphone at a normal voice level. The microphone is quite sensitive so it is not necessary to raise your voice or shout.
3. Release the **PTT** key when you have finished talking.

When transmitting, the status LED lights Red and the  icon appears on the LCD.

RECEIVING

When there are no incoming signals, the TX6600PRO will remain in standby mode with the receiver muted. If the battery save function has been enabled it will also sleep for short periods of time to conserve battery power.

When a signal is received, the squelch will open and the signal will be heard in the speaker. During this time, adjust the volume control for a comfortable listening level. If no further signals are received, the squelch will close and the unit will return to standby mode.

Busy indicator

Whenever the channel is busy the  icon will appear on the display and the status LED on the top of the radio will light Green.

NOTE: *If your radio has Silent or Quiet mode enabled, the  icon may appear but you might not hear any sound from the speaker. This indicates that others are sharing the channel, but their calls are not meant for you. For this reason you should check whether the channel is busy BEFORE transmitting to ensure you do not accidentally talk over someone else.*







*Alternatively, you can enable **Busy Lockout** in your radio's Menu which will automatically inhibit the **PTT** key whenever the channel is busy. Please refer to the section on **Busy Lockout**.*

SIGNAL STRENGTH METER

The TX6600PRO has a digital signal strength meter that is, by default, displayed in logarithmic format at the bottom of the LCD as numbers from 0 to 9+ (with 9+ being the strongest).

The signal meter display can be changed via the **DISPLAY** setting in the main menu to show the signal strength in linear format (with 0 being a weak signal and 60 being a strong signal).

To switch between a logarithmic and a linear signal meter:

1. Hold the  key to access the menu. The last selected menu item will be displayed.
2. Rotate the **Channel** knob or press the   keys until DISPLAY is displayed.
3. Press the  key.
4. Rotate the **Channel** knob or press the   keys to select either S-MET or S-LIN.
 - S-MET: Logarithmic format
 - S-LIN: Linear format
5. When the desired setting is displayed, press the  key to exit the menu or wait a few seconds for the menu to time-out.

NOTE: You will notice that there are additional options available under the DISPLAY menu. To review them all, please refer to **DISPLAY OPTIONS** further below.

SQUELCH

The Squelch is used to eliminate any annoying background noise when there are no signals present. The TX6600PRO features a preset Squelch system. The Squelch level has been preset to provide optimum performance in most situations but can be adjusted through the menu.

The Squelch can be opened or closed by pressing the SQL key. When the Squelch is open the receiver's background noise can be heard, the  icon is displayed and the status LED lights Green.

When the Squelch is closed, the radio remains quiet when there are no signals present but any incoming signals will override the Squelch and be heard in the speaker.

NOTE: If the SelCall QUIET mode or CTCSS/DCS Silent mode is enabled, all signals will be heard while the squelch is open.

To Open the Squelch

Briefly press the SQL key. SQLCH and OPn are displayed briefly, the  icon appears and the status LED lights green indicating the squelch is open. If there are no signals present you will hear the receiver's background noise.



To Close the Squelch

Briefly press the SQL key again. SQLCH and CLS are displayed briefly, the  icon disappears and the status LED is extinguished indicating the squelch is closed. If there are no signals present, the receiver will become quiet.



SQUELCH LEVEL

The Squelch level sets the sensitivity of the Squelch to incoming signals. The level can be set to suit your operating environment. The TX6600PRO has nine preset Squelch sensitivity settings from 1-9.

- Squelch level 1 is the most sensitive setting. It will allow the Squelch to open on very weak signals but it will also be more sensitive to unwanted signals or local interference.
- Squelch level 9 is the least sensitive setting. Your radio will be less affected by local interference but incoming signals will need to be much stronger to open the squelch.

The default setting is 3 which should suit most conditions.

The squelch level can be adjusted from either the **Channel** knob or the menu.

To adjust the Squelch level from the Channel knob:

1. Press the **Channel** knob. **SQLCH** will be displayed along with the present squelch level setting.
2. Rotate the **Channel** knob to adjust the squelch level from 1 to 9.
3. When the desired setting is displayed, press the **Channel** knob or wait a few seconds for the menu to time-out to save and return to normal operation.

To adjust the Squelch level from the Menu:

1. Hold the **MENU** key to access the menu. The last selected menu item will be displayed.
2. Rotate the **Channel** knob or press the **▲** **▼** keys until **SQ LCH** is displayed.
3. Press the **MENU** key.
4. Rotate the **Channel** knob or press the **▲** **▼** keys to adjust the squelch level from 1 to 9.
5. When the desired setting is displayed, press the **MENU** key to exit the menu or wait a few seconds for the menu to time-out.

PRIORITY CHANNEL

The Priority Channel feature allows you to store two channels as Priority Channels that can be instantly recalled at the press of a key. These can be used to provide instant access to your working channel, your local repeater channel or any other favourite channel.

Priority Channels are programmed into the side keys below the PTT key. The upper key holds Priority Channel 1 and the lower key holds Priority Channel 2.

To store the Priority Channel

1. Select the required channel using the **Channel** knob or press the **▲** **▼** keys.
2. Press and hold the desired Priority Channel key. **SET PRI1** or **SET PRI2** will be displayed and the channel number will flash. The radio will then return to normal operation.



To recall the Priority Channel

Briefly press the desired Priority Channel key. The TX6600PRO will immediately switch to the selected Priority Channel and **PRI1** or **PRI2** will be displayed briefly to indicate the Priority Channel memory you have selected.

DUAL WATCH

Dual Watch allows you to scan between the selected channel and the last selected Priority Channel. Before using Dual Watch you will need to program a channel into the Priority Channel memory (see Priority Channel description above).

To start Dual Watch

1. Choose your selected channel using the **Channel** knob or press the ▲▼ keys.
2. Press the **Red** key on the top panel to activate Dual Watch.
3. DW – xx is displayed (where xx is your last selected Priority Channel) and the ↻ icon will animate. The radio is now watching both the selected channel and the last selected Priority Channel.



NOTE: When Dual Watch is active, you can change the selected channel at any time by rotating the **Channel** knob or pressing the ▲▼ keys. Your radio will continue to monitor the last selected Priority Channel and your newly selected channel.



To exit Dual Watch

1. Press the **Red** key. Dual watch will stop and the radio will return to normal operation.



TRIPLE WATCH

Triple Watch allows you to scan between the selected channel, Priority Channel 1 and Priority Channel 2. Before using Triple Watch you will need to program channels into both the Priority Channel 1 and Priority Channel 2 memories (see Priority Channel description above).

To start Triple Watch

1. Choose your selected channel using the **Channel** knob or press the   keys.
2. Hold the **Red** key on the top panel to activate Triple Watch.
3. **TW - xx** will appear (where **xx** will alternate between your two Priority Channels) and the  icon will animate. The radio is now watching all three channels.



NOTE: When Triple Watch is active, you can change the selected channel at any time by rotating the **Channel** knob or pressing the   keys. Your radio will continue to monitor your two Priority Channels as well as your newly selected channel.

To exit Triple Watch

1. Press the **Red** key. Triple watch will stop and the radio will return to normal operation.

SCAN GROUPS

The **OS/GS** key is used to select a scan group for scanning. Available scan groups are Open Scan 1, Open Scan 2, Group Scan and Network Scan.

To cycle between scan groups

Briefly press the  key followed by the  key. **OPEN1**, **OPEN2**, **GROUP** or **NETWK** will be displayed briefly.

Please refer to the **SCANNING** section for further details on the operation of each scan group.

NOTE: Network scan (**NETWK**) is disabled by default and if required will need to be enabled through the radio's menu. It will not appear under the **OS/GS** key until it has been enabled (see **NETWORK SCAN** later in this manual).

DUPLEX

The **DUP** key is used to enable duplex operation, allowing the TX6600PRO to operate through a repeater. Repeaters are usually installed in a high location and automatically re-transmit your signal over a wider area, providing greatly increased range.

Simplex/Duplex Range Comparison

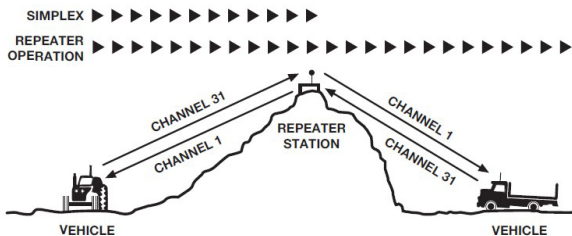









The Duplex function operates only on designated repeater channels. These are channels 1 – 8 and 41 – 48. When Duplex is enabled on one of these channels, the TX6600PRO will receive on the selected channel but will transmit 30 channels higher. i.e. if channel 1 is selected the TX6600PRO will receive on channel 1 but transmit on channel 31.

See the table below.

Selected Channel	1	2	3	4	5	6	7	8	41	42	43	44	45	46	47	48
Receive Channel	1	2	3	4	5	6	7	8	41	42	43	44	45	46	47	48
Transmit Channel	31	32	33	34	35	36	37	38	71	72	73	74	75	76	77	78

You can enable or disable Duplex on individual channels. This allows you to use Duplex only on repeater channels that are allocated in your area while the rest of the channels can be used as normal simplex channels for direct radio-to-radio communications.







To enable or disable Duplex on a repeater channel

1. Select the required channel 1 – 8 or 41 – 48.
2. Look for the  Duplex icon on the left of the display.
 - i. If the  icon is visible, Duplex is currently enabled on the selected channel. To disable Duplex operation, press  then . The  icon will disappear. The channel is now operating in Simplex mode.
 - ii. If the  icon is NOT visible, the selected channel is not enabled for duplex operation. To enable Duplex, press  then . The  icon will appear. The channel is now operating in Duplex mode.

PRO KEY

The PRO key is a programmable key that can be used to provide a shortcut to a user-assigned function. Once a function has been assigned, pressing the  key will immediately activate that function.

To assign a function to the PRO key:

1. Hold the  key to access the menu. The last selected menu item will be displayed.
2. Rotate the **Channel** knob or press the   keys until PROKEY is displayed.
3. Press the  key.
4. Rotate the **Channel** knob or press the   keys to select from DW/TW, SQLLVL, DISP, RECALL, PWRSAV or BEEP (see list below for details).
5. When the desired function is displayed, press the  key to exit the menu or wait a few seconds for the menu to time-out.

A full description of the operation of each of these functions is included elsewhere in this manual.

PRO KEY ASSIGNMENTS

SQLVL:

PRESS the  key to select the **Squelch Level** option.

HOLD the  key: No function.

DISP:

PRESS the  key repeatedly to cycle through the **DISPLAY** options.

HOLD the  key to toggle the **SelCall Alpha** display mode.

RECALL:

PRESS the  key to recall a stored channel.

HOLD the  key to store the selected channel for later recall.

PWRSV:

PRESS the  key to cycle through the **Power Save** options.

HOLD the  key to cycle through the **backlight** options.

BEEP:

PRESS the  key to cycle through the **BEEP** options.

HOLD the  key to switch Channel Announce **ON** or **OFF**.

DW/TW:

PRESS the  key to activate or deactivate the **Dual Watch** function.

HOLD the  key to activate or deactivate the **Triple Watch** function.

LOCK KEY

The LOCK key is used to lock the keypad to prevent unintentional key presses from altering your radio settings. When the keys are locked, only PTT, LOCK, F and the On/Off Volume control will continue to function. If any other key is pressed, 'LOCKED' is displayed.

To lock the keys

Press the **MENU** key followed by the **CALL LOCK** key. 'LOCKED' will appear on the display for several seconds. The keypad will now remain locked even if the radio is turned Off and On again.

To unlock the keys

Briefly press the **MENU** key followed by the **CALL LOCK** key. 'UNLOCK' will be displayed for a few seconds. The keypad is now restored to normal operation.

TRANSMIT POWER

The **PWR** key is used to switch the transmitter power from a high power of 5W down to a low power of 1W or an ultra-low power of 100mW. Using a lower transmitter power for short range communications will conserve battery power and can increase battery life quite dramatically.

To set the transmitter power:

Briefly press the **MENU** key followed by the **QUIET PWR** key to cycle through the transmitter power levels. The radio will display 5W, 1W or 100mW. When 1W is selected the **LO** icon is displayed. When 100mW is selected the **ULO** icon is displayed.

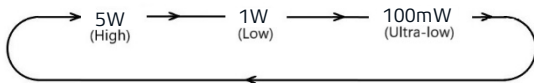

BUSY LOCKOUT

The Busy Lockout function detects when another signal is being transmitted on the channel and prevents your radio from accidentally transmitting over the other signal. When enabled, Busy lockout will be active if you are using Silent mode with CTCSS/DCS (the **S** or **S^{nr}** icon is displayed) or Quiet mode with Selcall (the **Q** icon is displayed) as your radio can remain quiet even when the channel is busy in these modes.

When Busy Lockout is active, if the channel is busy and you press the **PTT** key the radio will emit a warning beep and the  icon won't be displayed.

If you get a Busy Lockout alarm when you press the **PTT** key, release the **PTT** key and look for the  icon on the display as an indicator that the channel is in use. If so, simply wait until the channel is clear and press the **PTT** key again.

To enable Busy Lockout:

1. Hold the **MENU** key to access the menu. The last selected menu item will be displayed.
2. Rotate the **Channel** knob or press the **▲ ▼** keys until **BUSYLK** is displayed.
3. Press the **MENU** key.
4. Rotate the **Channel** knob or press the **▲ ▼** keys to select **ON** or **OFF**.
5. When the desired setting is displayed, press the **MENU** key to exit the menu or wait a few seconds for the menu to time-out.

NOTE: You can also press the **SQUELCH** key to open the Squelch and listen for signals on the channel before transmitting.

TIME-OUT TIMER

The TX6600PRO has a built-in time-out timer that automatically limits transmissions to a maximum of 3 minutes of continuous operation. This feature is required by the ACMA to prevent accidental blocking of the frequency should your **PTT** key become jammed or be otherwise pressed accidentally.

When the time-out timer activates, the transmission will stop, the radio will emit a long beep, and **TXTIMEOUT** will be displayed. Once the **PTT** key has been released normal operation will be restored.

ROGER BEEP

The Roger Beep setting applies a short tone to the end of your transmission to alert the receiving party that your transmission has ended.

To enable or disable the Roger Beep tone:







1. Hold the **MENU** key to access the menu. The last selected menu item will be displayed.
2. Rotate the **Channel** knob or press the **▲ ▼** keys until **RGBEEP** is displayed.
3. Press the **MENU** key.
4. Rotate the **Channel** knob or press the **▲ ▼** keys to select **OFF** or **ON**.

5. When the desired setting is displayed, press the  key to exit the menu or wait a few seconds for the menu to time-out.

MICROPHONE GAIN

The microphone gain boosts your voice input level at the microphone. If you are quietly spoken or are operating in a quiet environment where you cannot talk at a normal voice level, you can increase the microphone gain to make your voice sound clearer.

To adjust microphone gain:

1. Hold the  key to access the menu. The last selected menu item will be displayed.
2. Rotate the **Channel** knob or press the   keys until MIC G is displayed.
3. Press the  key.
4. Rotate the **Channel** knob or press the   keys to select a microphone level from 0 to 9. The default setting is 0.
5. When the desired setting is displayed, press the  key to exit the menu or wait a few seconds for the menu to time-out.

VOICE SCRAMBLER

Your TX6600PRO incorporates a simple voice scrambler using band inversion technology. The scrambler is compatible with other GME radios and with most scramblers used by other manufacturers, allowing you to enjoy scrambled communications with owners of both GME and non-GME radios.

Once the scrambler has been activated your transmission and reception will only be intelligible to others using the same scrambler technology. When enabled the scrambler is activated across all channels and must be deactivated to return to normal voice operation.

Note: *The ACMA does not allow scrambling on the emergency (5 and 35), calling (11) or repeater input (30-38, 70-78) channels. Communications will not be scrambled on these channels or while duplex mode is activated even if the scrambler function is enabled.*

To enable or disable the Scrambler:

1. Hold the **MENU** key to access the menu. The last selected menu item will be displayed.
2. Rotate the **Channel** knob or press the **▲** **▼** keys until **SCRAMB** is displayed.
3. Press the **MENU** key.
4. Rotate the **Channel** knob or press the **▲** **▼** keys to select **ON** or **OFF**.
5. When the desired setting is displayed, press the **MENU** key to exit the menu or wait a few seconds for the menu to time-out.

NARROW BAND FILTER

The TX6600PRO receiver is fitted with a user-selectable bandwidth filter that allows the receiver to be adjusted for either wide or narrow band reception on channels 1 - 40. This feature provides additional compatibility with older 40-channel radios. Switching the filter Off increases the tolerance of the TX6600PRO receiver to older wideband 40 channel radios or to signals that might be slightly off frequency. Switching the filter On increases the selectivity of the receiver on channels 1 - 40 which can help reduce interference from strong interfering signals on adjacent channels.

To select the Narrowband Filter:







1. Hold the **MENU** key to access the menu. The last selected menu item will be displayed.
2. Rotate the **Channel** knob or press the **▲** **▼** keys until **NBFILT** is displayed.
3. Press the **MENU** key.
4. Rotate the **Channel** knob or press the **▲** **▼** keys to select **ON** or **OFF**.
5. When the desired setting is displayed, press the **MENU** key to exit the menu or wait a few seconds for the menu to time-out.

SILENT SQUELCH TAIL

The Squelch Tail is the short burst of noise that is heard in the speaker at the end of a transmission before the Squelch closes. To some it is a reassuring confirmation that it is their turn to transmit but in some applications it may be an annoyance especially when listening through an earpiece or headphones.

The Silent Squelch Tail function removes this Squelch tail, reducing it to a faint click as the Squelch closes.

To enable or disable the Silent Squelch Tail:

1. Hold the  key to access the menu. The last selected menu item will be displayed.
2. Rotate the **Channel** knob or press the   keys until **SQLTAIL** is displayed.
3. Press the  key.
4. Rotate the **Channel** knob or press the   keys to select **ON** or **OFF**.
5. When the desired setting is displayed, press the  key to exit the menu or wait a few seconds for the menu to time-out.

DYNAMIC VOLUME CONTROL

The modulation levels of signals heard on the UHF CB band may vary considerably resulting in noticeable differences in received audio volume between stations. This is particularly apparent now that both wide and narrowband transmissions are sharing channels 1 - 40. Generally users have compensated for these differences by adjusting the volume control for each incoming signal.

The TX6600PRO has a unique GME feature called Dynamic Volume Control (DVC) that automatically compensates for these variations in received audio level. When activated, this feature automatically adjusts the received audio level resulting in a constant audio output level to the speaker.

To enable Dynamic Volume Control

1. Hold the **MENU** key to access the menu. The last selected menu item will be displayed.
2. Rotate the **Channel** knob or press the **▲ ▼** keys until **DYNVOL** is displayed.
3. Press the **MENU** key.
4. Rotate the **Channel** knob or press the **▲ ▼** keys to select **ON** or **OFF**.
5. When the desired setting is displayed, press the **MENU** key to exit the menu or wait a few seconds for the menu to time-out.

LCD BACKLIGHT

The LCD is backlit for easy viewing in low light conditions. Whenever a key is pressed the backlight will switch on. After 5 seconds of inactivity it will switch off again automatically to conserve power.

The backlight settings can be adjusted in the menu.

To adjust the backlight settings:







1. Hold the **MENU** key to access the menu. The last selected menu item will be displayed.
2. Rotate the **Channel** knob or press the **▲ ▼** keys until **BACKLT** is displayed.
3. Press the **MENU** key.
4. Rotate the **Channel** knob or press the **▲ ▼** keys to select **ON**, **OFF** or **AUT**.
 - **ON:** The backlight is always On
 - **OFF:** The backlight is always Off
 - **AUT:** The backlight will switch on when a key is pressed but will switch off automatically after 5 seconds.
5. When the desired setting is displayed, press the **MENU** key to exit the menu or wait a few seconds for the menu to time-out.

BEEPS

The TX6600PRO uses Beeps to provide audible feedback whenever a key is pressed or to notify you of various alarms and timers.

The beep setting can be adjusted in the menu.

To adjust the Beep setting:

1. Hold the  key to access the menu. The last selected menu item will be displayed.
2. Rotate the **Channel** knob or press the   keys until **BEEP** is displayed.
3. Press the  key.
4. Rotate the **Channel** knob or press the   keys to select **ON**, **OFF** or **ALT**.
 - **ON:** The radio will beep whenever a key is pressed or when an alert is required.
 - **OFF:** All Beeps are inhibited.
 - **ALT:** The radio will only beep when an alert is required. Key beeps are inhibited.
5. When the desired setting is displayed, press the  key to exit the menu or wait a few seconds for the menu to time-out.

NOTE: If both **Channel Announce** and **Beep** are set to ON, channel announcements will override key beeps when changing channels.

CHANNEL ANNOUNCE

Channel Announce provides an audible voice that speaks the channel number whenever a channel is selected. Channel Announce has two settings: ON or OFF. When Channel Announce is set to ON, the channel number will be announced whenever a channel is selected.

NOTE: If Key Beeps are switched ON, Channel Announcements will override the key beeps when changing channels.

To activate Channel Announce:

1. Hold the **MENU** key to access the menu. The last selected menu item will be displayed.
2. Rotate the **Channel** knob or press the **▲** **▼** keys until CH ANN is displayed.
3. Press the **MENU** key.
4. Rotate the **Channel** knob or press the **▲** **▼** keys to select ON or OFF.
5. When the desired setting is displayed, press the **MENU** key to exit the menu or wait a few seconds for the menu to time-out.

DISPLAY OPTIONS

The DISPLAY option allows you to choose the information that is displayed on the LCD in the space below the channel number. The default setting is S-MET which displays the incoming signal strength in logarithmic format using values from 0 - 9+.

To select a different Display option:

1. Hold the **MENU** key to access the menu. The last selected menu item will be displayed.
2. Rotate the **Channel** knob or press the **▲** **▼** keys until **DISPLAY** is displayed.
3. Press the **MENU** key.
4. Rotate the **Channel** knob or press the **▲** **▼** keys to select one of the options listed below.
 - **S-MET:** Displays the incoming signal strength in the traditional logarithmic format using values from 0 - 9+.
 - **S-LIN:** Displays the incoming signal strength in linear format.
 - **BATT V:** Displays the battery voltage.
 - **CHNAME:** Displays the name associated with the selected channel.
 - **RXFREQ:** Displays the selected channel's receiver frequency.
 - **TXFREQ:** Displays the selected channel's transmitter frequency.
 - **FREQ:** Displays the selected channel's receiver frequency when receiving and the transmitter frequency when transmitting.

- **IDNAME:** Displays the alpha name associated with your radio's own SelCall Ident. If a name has not been applied, it displays the radio's own SelCall Ident instead.
 - **ID NO:** Displays the radios own SelCall Ident.
 - **OFF:** Displays nothing in the space below the channel number.
5. When the desired setting is displayed, press the **MENU** key to exit the menu or wait a few seconds for the menu to time-out.

Examples



NOTE: The display option can be set separately for CB and Receive-only channels by first selecting a channel of the type you wish to edit, then using the DISPLAY menu as above.

MESSAGE TEXT

The Message Text option enables or disables verbose messages that appear on the display when some functions are selected. Generally these options are also associated with an icon or some other indicator.

For example, when adding the selected channel to the scan memory, the message **SCANCH ON** is displayed alongside the  icon. Similarly opening the squelch with the **Squelch** key displays **SQ LCH OPn** alongside the  icon.

If desired these text messages can be switched off so that only the associated icon is displayed.

To enable or disable the Message Texts:

1. Hold the **MENU** key to access the menu. The last selected menu item will be displayed.
2. Rotate the **Channel** knob or press the **▲** **▼** keys until **MSGTXT** is displayed.
3. Press the **MENU** key.
4. Rotate the **Channel** knob or press the **▲** **▼** keys to select **ON** or **OFF**.
5. When the desired option is displayed, press the **MENU** key to exit the menu or wait a few seconds for the menu to time-out.

POWER SAVE

The Power Save function is designed to conserve power and extend the battery life by letting the radio sleep during periods of inactivity. If you intend to use your TX6600PRO for long periods of time between charges you should consider using the power saving mode.

The Power Save option is switched off by default.

To select the Power Save options:

1. Hold the **MENU** key to access the menu. The last selected menu item will be displayed.
2. Rotate the **Channel** knob or press the **▲** **▼** keys until **PWRSAV** is displayed.
3. Press the **MENU** key.
4. Rotate the **Channel** knob or press the **▲** **▼** keys to select **OFF**, **LO** or **HI**.
 - Select **OFF** to switch the Power Save function Off. The radio will remain active at all times and will draw the most amount of power from the battery.
 - Select **LO** to enable the Power Save function at a conservative setting. The radio will sleep during periods of inactivity but will respond quickly to incoming signals.
 - Select **HI** to enable the Power Save function at a more aggressive setting. The radio will conserve the most amount of power but may not be as responsive to incoming signals.
5. When the desired setting is displayed, press the **MENU** key to exit the menu or wait a few seconds for the menu to time-out.









For additional tips on conserving power please read the section “Conserving your Battery Power” later in this manual.

RADIO INFORMATION

The menu has an INFO option to provide hardware, firmware and identity information about your radio.

To view your radio information:

1. Hold the **MENU** key to access the menu. The last selected menu item will be displayed.

2. Rotate the **Channel** knob or press the   keys until **INFO** is displayed. Press the  key to access the sub-menu.
3. Rotate the **Channel** knob or press the   keys to select one of the available sub-menu options. **MODEL**, **SERNO**, **FWVER**, **HWVER**, or **OWNID** will be displayed. (see list below for details).
4. With the desired option displayed, press the  key to view the selected information.
5. Hold the  key to return to the sub-menu or press the  key to exit and return to normal operation.





Available INFO Options

- **MODEL**: Displays your radio's model name.
- **SERNO**: Displays your radio's serial number.
- **FWVER**: Displays your radio's firmware (operating software) version.
- **HWVER**: Displays your radio's hardware (PCB assembly) version.
- **OWNID**: Displays your radio's own SelCall Ident.

FACTORY RESET

The TX6600PRO has a factory reset option that allows you to restore the radio back to its out-of-the-box settings. Activating the factory reset will delete any changes you have made to the radio including any receive-only channels, scan memories and CTCSS/DCS settings and will reset all the menu settings to their defaults.

To activate the factory reset procedure:

1. Hold the  key to access the menu. The last selected menu item will be displayed.
2. Rotate the **Channel** knob or press the   keys until **RESET** is displayed then press .
3. The channel number will change to --- and **RESET? HOLD SIDE-BOTTOM** will scroll on the display.
4. Hold the **Side-Bottom** button (below the **PTT** Key) for several seconds until the radio beeps.
5. **RESET? HOLD TOP RED BUTTON** will scroll on the display.
6. Hold the top **RED** button for several seconds until the radio beeps.

7. **RESET** will again be displayed and the status LED will flash RED as the reset process begins. After a few seconds the radio will restart and normal operation will be restored on CB channel 1.

SCANNING

OVERVIEW

The TX6600PRO includes a Scan function that allows groups of user programmable channels to be scanned for signals. Channels can be scanned at over 45 channels per second. When a signal is found, scanning will pause to allow the signal to be heard and will resume scanning when the channel is clear again.

Scan Groups

The TX6600PRO features four scan groups – Open Scan1, Open Scan2, Group Scan and Network Scan.

To select a scan group, press the **MENU** _F key followed by the **SCAN** _{OS/GS} key. Each press will cycle through the available groups and **OPEN1**, **OPEN2**, **GROUP** or **NETWK** will be displayed briefly as each group is selected.

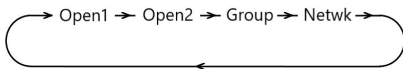

NOTE: **NETWK** will not appear under the **SCAN** _{OS/GS} key unless **NETWORK SCAN** has been enabled in the menu (**NETWORK SCAN** is switched off by default)



TIP: To quickly determine which channels are currently programmed into any selected scan group.

1. Check that the radio is not already scanning. If it is, briefly press the **SCAN** _{OS/GS} key to stop the scan.
2. Press **MENU** _F then **SCAN** _{OS/GS} to cycle to the desired Scan Group (**OPEN1**, **OPEN2**, **GROUP** or **NETWK** will be displayed briefly).
3. Briefly press the **MENU** _F key. F will be displayed.
4. Rotate the **Channel** knob or press the **▲** **▼** keys to step through the channels. Only channels that are stored in the selected scan group will be displayed.
5. When finished, press the **MENU** _F key to exit.

ADDING AND REMOVING SCAN CHANNELS

To ADD or REMOVE channels in a Scan Group:

1. Check that the radio is not already scanning. If it is, briefly press the **SCAN** key to stop the scan.
2. Press **MENU** then **SCAN** to cycle to the desired Scan Group (**OPEN1**, **OPEN2**, **GROUP** or **NETWK** will be displayed briefly).
3. Select the desired channel by rotating the **Channel** knob or press the **▲** **▼** keys.
 - i. If the selected channel is in the scan memory the  icon will be visible.

To **REMOVE** the channel, press and hold the **SCAN** key. 'SCANCH OFF' will be displayed briefly and the  icon will disappear indicating the channel is no longer in memory.
 - ii. If the  icon is not visible, the selected channel is not in the scan memory.

To **ADD** the channel, press hold the **SCAN** key. 'SCANCH ON' will be displayed briefly and the  icon will appear to confirm the channel is now in memory.



Using Auto Skip

When scanning, if the scan constantly pauses on the same busy channel, briefly press the **▲** **▼** keys to skip over that channel and temporarily remove it from the scan group for 30 seconds. The scan will then continue from the next channel in the sequence. After 30 seconds the skipped channel will be reinstated in the scan sequence.

If the unwanted busy channel continues to interrupt the scan even after the 30 second skip period has elapsed, hold the **SCAN** key while the radio is paused on that channel. The 'nuisance' channel will be completely removed from the scan group for the duration of that scan session. To restore the channel, simply stop and restart the scan session using the **SCAN** key. Turning the radio Off then On again will also restore the channel.

OPEN SCAN MODE

Open Scan allows any of the channels to be scanned for activity in an ascending sequence (i.e. from the lowest channel to the highest). If a busy channel is found, the scan will pause to allow the signal to be heard. Once the channel has been clear for 5 seconds, the scan will resume automatically.

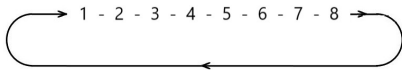

e.g. Scanning channels 1 – 8 in Open Scan.

The TX6600PRO has two separate Open Scan memories labelled **OPEN1** and **OPEN2**. Their operation is identical but each can be independently programmed with a range of different channels. The **OPEN1** scan memory has all 80 channels factory-programmed. Any channels that are not required can be easily removed. The **OPEN2** scan memory is factory-programmed with all the repeater channels.

Selecting Open Scan

Briefly press **MENU** then **SCAN** to cycle through the scan groups until **OPEN1** or **OPEN2** is displayed.

Programming Open Scan channels

ADD or REMOVE your desired channels as described above.

To Start Scanning

Briefly press the **SCAN** key. The  icon will animate and the channel numbers will change rapidly as the channels are scanned. During this time the display will show OS-xx where OS indicates Open Scan and xx indicates your working channel (your last-selected channel). The radio will return to this channel when you stop the scan.

To Stop Scanning

Briefly press the **SCAN** key. The  icon animation will stop and the radio will return to your working channel.

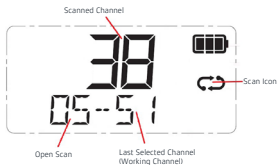

NOTE: If there are less than two channels programmed into the Scan memory when you press the **SCAN** key, an error beep will be heard and **SCANERROR** will be displayed.

Operating in the Open Scan mode

If a busy channel is found, the scan will pause on that channel to allow the signal to be heard and will remain there for as long as the channel remains busy and for 5 seconds after it has cleared. The scan will then resume automatically.

To temporarily remove a constantly busy channel from the scan group, use the **▼** **▲** keys to activate the **Auto Skip** feature.

Transmitting while scanning

Press the **PTT** key while scanning to talk on your working channel (displayed at the bottom of the LCD). When the **PTT** key is released, scan will resume after the channel has had 5 seconds of inactivity.

Press the **PTT** key while the scan is paused on a busy channel to talk on the busy channel. The busy channel then becomes your new working channel which will be displayed on the bottom of the LCD.

If your radio is scanning and you need to use your Priority Channel (for an urgent call or an emergency), briefly press the **PRI1** or **PRI2** keys. The scan will be cancelled, and the radio will jump straight to the selected Priority Channel.

GROUP SCAN MODE

Group Scan allows you to scan several channels for activity while also monitoring your selected Priority Channel every fifth channel. The receiver will continue to scan the other channels only while there are no signals on the Priority Channel. If a signal appears on the Priority Channel it will override any signals being received on any of the other channels. In addition, if you press the PTT key at any time, the radio will always transmit on the Priority Channel.

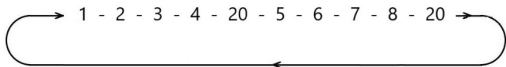

e.g. Scanning channels 1 – 8 with Priority Channel 20 in Group Scan

Selecting Group Scan

Briefly press **MENU** then **SCAN** to cycle through the scan groups until **GROUP** is displayed.

Programming Group Scan channels

ADD or REMOVE your desired channels as described above.

To Start Scanning

Briefly press the **PRI1** or **PRI2** key to select the desired Priority Channel.

Briefly press the **SCAN** key. The  icon will animate and the channel numbers will change rapidly as the channels are scanned. During this time the display will show GS-xx where GS indicates Group Scan and xx indicates the selected Priority Channel.

To Stop Scanning

Briefly press the **SCAN** key. The  icon animation will stop and the radio will return to your selected Priority Channel.



NOTE: If there are less than two channels programmed into the Scan memory when you press the **SCAN** key, the command will be ignored.

Operating in the Group Scan mode

In Group Scan mode, the TX6600PRO scans all the channels programmed into the Group Scan memory with the selected Priority Channel being scanned every fifth channel.

If a signal is heard on a scan channel, the scan will pause on that channel and remain there while the channel is busy and for 5 seconds after it has become clear, as long as there are no signals on the selected Priority Channel. During this time the receiver will continue to check the Priority Channel for signals once a second, resulting in a series of small 'breaks' in the reception of the scan channel. Once the signal has gone, the radio will resume scanning.

If a signal appears on the Priority Channel at any time (even when paused on a scan channel) the receiver will switch straight to the Priority Channel. If you were listening to a signal on the scan channel at the time, the radio will beep to alert you to the change in channel. It will then stay on the Priority Channel for as long as it is busy. During this time you can transmit on the Priority Channel in the usual way. Once the activity on the Priority Channel has ceased for 5 seconds, the radio will resume scanning the other channels.

To temporarily remove a constantly busy channel from the scan group, use the   keys to activate the **Auto Skip** feature.

Transmitting in Group Scan mode

To transmit on the Priority Channel, press the PTT key at any time. The radio will switch straight to the Priority Channel. When you have finished talking, the radio will resume scanning after 5 seconds of inactivity on the Priority Channel.

To transmit on a group scan channel, you must exit the scan mode, select the required channel then talk in the usual way.

When your conversation is finished, press the  key to resume scanning.

NETWORK SCAN MODE



Network Scan allows a group of radio users to maintain communications even when the band is congested. To achieve this, all members of the Network Scan group must share a common CTCSS/DCS tone and a common set of Network Scan channels. Once activated, Network Scan's intelligent scanning algorithm keeps track of clear channels within your scan group. When any member of the group transmits, their radio automatically selects a clear channel to transmit on. Other radios scanning in the same Network Scan group will then lock onto that channel allowing all members of the group to join the conversation. If a signal from someone who is not part of your Network Scan group appears on the chosen channel, the group will automatically switch to a new clear channel at the next transmission. In this way the group can continue to communicate with minimal interference to or from other users.

Enabling Network Scan

Network Scan is normally switched off by default but can be enabled through the menu.

NOTE: When you enable Network Scan you must also choose a suitable CTCSS or DCS tone to be used by your Network Scan group. All members of your Network Scan group must use this same tone.

To enable Network Scan and select a CTCSS/DCS Tone

1. Hold the  key to access the menu. The last selected menu item will be displayed.
2. Rotate the **Channel** knob or press the   buttons until **NETSCN** is displayed.

3. Press the **MENU** key.
4. If Network Scan is switched off, 'OFF' will be displayed. Rotate the **Channel** knob or press the **▲** **▼** keys to enable Network Scan and select a suitable CTCSS/DCS tone.
 - i. Rotate the **Channel** knob clockwise or press the **▲** key to enable CTCSS and select CTCSS tones from 01 to 50.
 - ii. Rotate the **Channel** knob counter-clockwise or press the **▼** key to enable DCS and select DCS tones from 001 to 104.

NOTE: Advancing upwards past CTCSS tone 50 will automatically cycle into the DCS tone set. Similarly, stepping downwards below DCS tone 001 will automatically cycle into the CTCSS tone set.
5. When the desired CTCSS/DCS tone is displayed hold the **MENU** key to exit or wait for the menu to time-out.

Refer to the CTCSS/DCS tone table in this manual for details of tone values.

NOTE: Selecting Netscan CTCSS/DCS tones does not affect the Global CTCSS/DCS tone setting used for normal CTCSS/DCS operation.

To Select Network Scan for scanning

Briefly press **MENU** then **SCAN** to cycle through the scan groups until **NETWK** is displayed.

Programming channels into Network Scan

All radios in your Network Scan group must have the same channels programmed into their Network Scan memory. Your radio's Network Scan memory has been factory programmed with 43 of the available 80 channels. The remaining 37 channels, consisting of the 32 repeater input/output channels, 2 telemetry channels and 3 reserved channels, have not been included to minimise the risk of interference to other services on these channels.

To add or remove Network Scan channels

Follow the procedure to ADD or REMOVE your desired channels as described above.

IMPORTANT: If adding channels to your Network Scan, please consider the following:

The transmitter on your radio is inhibited on channels 22, 23 and channels 61, 62, 63 as required by the ACMA. These channels are therefore unsuitable for use as Network Scan channels.

You should only include a designated repeater channel AFTER you have confirmed that the channel is not allocated to an active repeater in your area. If you inadvertently include an active repeater channel in your Network Scan, you or others in your Network Scan group may cause interference to other repeater users on that channel.

To Start Network Scan

Briefly press the **SCAN** key. The  icon will animate and the channel numbers will change rapidly as the channels are scanned. During this time the display will display 'NS -xxx' where xxx is the selected Network Scan CTCSS or DCS tone.



Network Scanning using CTCSS tone 22



Using Network Scan

When a member of the group transmits, their radio will automatically select a clear channel to transmit on. Other radios scanning in the same Network Scan group will locate the signal (identified by the group's Network Scan CTCSS/DCS code) and stop on the same channel allowing the transmission to be heard across the entire group. When the transmission ends, all radios in the group will immediately resume scanning.

Any member of the group who responds to the initial transmission will automatically re-use the same channel as long as the channel remains free of other signals. This allows the radios in the group to respond quickly to further transmissions from others in the group.

If a signal from outside your Network Scan group appears on the same channel, the channel will be discarded and a new clear channel will be selected at the next group-member transmission. The other radios scanning in the group will then locate the new channel, allowing the conversation to continue seamlessly without any input from the user.

To Stop Network Scan

Briefly press the  key. The animated  icon will stop. As long as the radio was not on a busy channel, it will return to the last channel you selected, otherwise it will stay on the busy channel.

Using Priority Channels with Network Scan

If you need to use your Priority Channel (for an urgent call or an emergency), briefly press the PRI1 or PRI2 key. The Network Scan will be cancelled, and the radio will jump straight to the selected Priority Channel. When your conversation has finished, press the  key to restore the Network Scan.

CTCSS AND DCS

CTCSS (Continuous Tone Coded Squelch System) and DCS (Digital Coded Squelch) are similar Squelch quieting systems that allow groups of users to share the same channel without disturbing each other. The CTCSS system uses 1 of 50 low frequency tones to open and close the Squelch on the radio. The DCS system is similar to CTCSS but uses 1 of 104 digital tones to control the Squelch.

Your choice of CTCSS or DCS will largely depend on which one is currently being used by other radios in your group. If neither system is currently in use, you can make your own choice as there is no difference in performance between the two systems.

NOTE: *Enabling CTCSS or DCS codes do not prevent others who are not using any codes from hearing your transmission.*

CTCSS Tone Set Compatibility

The GME CTCSS tone set comprises a table of 50 tones made up of the standard CCIR-38 Tone Set plus an additional 12 tones added to the end. If communicating with other brands of radios that only use the CCIR-38 tone set, you should select from one of the first 38 tones to ensure compatibility with these models. Refer to the CTCSS/DCS tone table in this manual for details of tone values.

IMPORTANT: *If communicating with other GME radios, you can choose from any of the 50 tones. However, please refer to the tone set tables listed in each radio's Instruction manual because, although the same 50 tones are available in all GME radios, the tones used in older GME models may be listed in a different order.*

Using CTCSS and DCS tones

NOTE: CTCSS/DCS tones are switched off by default. To use CTCSS or DCS you must first select a suitable CTCSS/DCS tone using the menu.

To enable or disable CTCSS or DCS

1. Hold the **MENU** key to access the menu. The last selected menu item will be displayed.
2. Rotate the **Channel** knob or press the **▲** **▼** keys until **SUBTONE** is displayed.
3. Press the **MENU** key.

NOTE: The factory setting displays **CTCSS** and **OFF** indicating CTCSS/DCS is switched Off.

4. Rotate the **Channel** knob clockwise or press the **▲** key to enable CTCSS and select CTCSS tones 01 to 50.
5. Rotate the **Channel** knob counter-clockwise or press the **▼** key to enable DCS and select DCS tones 001 to 104.
6. To disable **CTCSS/DCS**, select **OFF**.
7. To exit the menu, press the **MENU** key or wait a few seconds for the menu to time-out.



Silent Mode

Once you have selected a CTCSS or DCS code you can choose to enable Silent mode on selected channels. Once enabled, your selected channels will remain closed to all signals except those that are using the same code as your radio. Channels that do not have Silent mode enabled will remain open to all signals.

To Enable Silent Mode on a channel

1. Use the **Channel** knob or press the **▲** **▼** keys to select the desired channel.

2. Hold the Squelch key (top-side key above the PTT key). SILENT ON will appear briefly and an **S** (CTCSS) or **Snr** (DCS) icon will appear to indicate whether CTCSS or DCS is being used.



3. Repeat steps 1 & 2 to activate silent mode on other channels.

Channels that have silent mode enabled will now stay silent unless a signal containing your chosen CTCSS or DCS code is received.

NOTE: You may activate CTCSS on any channel except the emergency channel 5/35.

To deactivate Silent mode on a channel

1. Select the desired channel. The **S** (CTCSS) or **Snr** (DCS) icon should be visible on that channel.
2. Hold the Squelch key. The **Snr** (DCS) or **S** (CTCSS) icon will disappear from that channel.

The channel is now open to all incoming signals.

NOTE: Silent mode cannot be activated unless a CTCSS or DCS code has been selected via the menu. If CTCSS/DCS tones are set to 'OFF', any attempt to activate the Silent mode will be ignored.









TIP: When operating in Silent mode, you might see the  icon appear on the display but nothing will be heard because your Squelch is controlled by a CTCSS or DCS tone. During this time you can use the Squelch key to manually open the squelch, allowing you to listen on the channel for all signals.

To open the squelch, press the **SQUELCH** key. If signals with CTCSS or DCS are using the channel you will now be able to hear them in the speaker. If no signals are present you will hear the background hiss of an empty channel. Press the **SQUELCH** key again to close the Squelch.

Identifying another station's CTCSS or DCS code

To identify a CTCSS code being used by another station operating on your channel, use the following procedure:

1. Enable CTCSS/DCS on the selected channel by holding the **SQUELCH** key. **Snr** or **S** will appear on the display.

2. Hold the  key to access the menu. The last selected menu item will be displayed.
3. Turn the **Channel** knob or press the   keys to access the **SUBTONE** option.
4. Press the  key.
5. Use the   keys to step through the range of available CTCSS/DCS codes while the channel is busy. Press  for DCS tones or  for CTCSS tones. When the correct code is selected, the mute will open and you will be able to hear the signal in the speaker.

SELCALL

OVERVIEW

Selective Calling (SelCall) uses unique SelCall Identification numbers (Idents) to selectively call other radios. Each radio is identifiable by its own SelCall Ident allowing it to be called either individually or as part of a group. If your TX6600PRO's Ident is called by another radio, your radio will alert you to the call. If you are unavailable when the call is received, the callers Ident will be displayed on your radio allowing you to call them back on your return.

Your TX6600PRO is factory programmed with its own unique 5 digit SelCall Ident. You should make your SelCall Ident known to anyone who may need to call you using SelCall. If an incoming SelCall matches **your radio's Ident, your radio will alert you to the call.**

QUIET Mode

The QUIET mode works with the SelCall function to ensure the radio remains quiet to all incoming signals unless your SelCall Ident is received. In this way, your radio can monitor a busy channel without disturbing you, but still let you know when you are being called. When QUIET mode is enabled, you may see the  busy icon appear on the display indicating the channel is in use but nothing will be heard in the speaker.

The QUIET mode can be enabled on individual channels allowing you the freedom to choose which channels will remain quiet and which will stay open to all incoming signals. Once your SelCall Ident is received, the QUIET mode is cancelled allowing you to converse normally on the channel.

NOTE: You don't need to enable the QUIET mode to use SelCall. If you prefer to listen to all incoming conversations, you can still receive SelCalls on any channel even if the QUIET mode is not enabled.

SelCall Contacts

Your TX6600PRO supports up to 48 SelCall contacts. Contacts can be saved and recalled using the contact list or alternatively you can manually enter and dial a SelCall Ident directly through the CALL menu.

Ident or Alpha Name

SelCall Idents stored in your contact list can be allocated a 6 letter 'Alpha' name. If an incoming SelCall matches one of those in your radio's contact list, your radio can be set to display the name instead of the Ident. This makes it easier to identify the calling radio.

The following characters are available for use in Alpha Names.

PUNCTUATION	NUMBERS	LETTERS
-+*,_	1234567890	ABCDEFGHIJKLMN OPQRSTUVWXYZ

CALL MENU

The **CALL** menu provides access to all SelCall options. To access the SelCall options:

1. Press the **CALL LOCK** key. The SelCall sub-menu will be displayed.
2. Rotate the **Channel** knob or press the **▲ ▼** keys to cycle through the following sub-menu options:
 - **SAVED:** Review, Edit or Save SelCall Idents in your contact list
 - **OWNID:** Review or Edit your radio's own SelCall Ident
 - **DIAL:** Manually enter a SelCall Ident for sending
 - **RECNT:** Recall recently received or sent SelCall Idents

Editing your Own SelCall Ident

Your radio is shipped with its own unique 5 digit SelCall ID already programmed. If you wish you can change this to one of your own preference.

Note the new Ident you choose must have 5 digits.

1. Press **CALL LOCK** to enter the **CALL** Menu.
2. Rotate the **Channel** knob or press the **▲ ▼** keys to cycle to the **OWNID** option then press **MENU F** to select. **id** is displayed along with your radio's Ident or Alpha name.
3. Press **MENU F** to toggle between Ident and Alpha mode to select the Ident then hold **MENU F**. The right-hand digit will be flashing.
4. Rotate the **Channel** knob or press the **▲ ▼** keys to select the desired number in the flashing digit position.
5. Press **MENU F** to advance to the next position.
6. Repeat steps 4 & 5 to enter all 5 digits of your new SelCall Ident, then hold **MENU F** to save. The Ident will flash 3 times to confirm it has been saved.
7. To edit the Alpha Name, briefly press **MENU F** to toggle to the Alpha mode then hold **MENU F**. The left-hand character will be flashing.
8. Repeat steps 4 & 5 to edit the Alpha Name. When the desired label is displayed, hold **MENU F** to save. The Ident will flash 3 times to confirm it has been saved.
9. Press **CALL LOCK** to return to the CALL sub-menu.
10. Press **CALL LOCK** again to return to normal operation.

Saving a New SelCall Ident in your Contact List

1. Press **CALL LOCK** to enter the **CALL** Menu.
2. Rotate the **Channel** knob or press the **▲ ▼** keys to cycle to the **SAVED** option then press **MENU F** to select.
3. Rotate the **Channel** knob or press the **▲ ▼** keys (if necessary) to cycle through your contacts until '- FREE -' is displayed. This indicates the next available empty contact memory.
4. Hold **MENU F** to select this location.
 - If the edit field displays '00000' and the right-hand digit is flashing, the radio is in Ident mode.
 - If the edit field is blank and the left-hand character is flashing, the radio is in Alpha mode.
5. Rotate the **Channel** knob or press the **▲ ▼** keys to select the desired number or character in the flashing position.

- Press **MENU** to advance to the next position.
- Repeat steps 5 & 6 to enter all 5 Ident digits or up to 6 Alpha characters, then hold **MENU** to save. The field will flash 3 times to confirm it has been saved.
- Briefly press **MENU** to toggle between Ident and Alpha modes.
- Hold **MENU** to edit the new field.
- Repeat steps 5, 6 & 7 to enter the desired characters or numbers into the field.
- Hold **MENU** to save. The field will flash 3 times to confirm it has been saved.
- Press **CALL LOCK** to return to the **CALL** sub-menu.
- Press **CALL LOCK** again to return to normal operation.



'Saved' Menu



Empty Memory Location



Editing the SelCall Ident











Selecting the Alpha Name Field









Entering an Alpha Name

Editing an existing Contact

- Press **CALL LOCK** to enter the **CALL** Menu.
- Rotate the **Channel** knob or press the **▲** **▼** keys to cycle to the **SAVED** option then press **MENU** to select.
- Rotate the **Channel** knob or press the **▲** **▼** keys to cycle to the desired contact.
- Briefly press **MENU** to toggle between Alpha and Ident modes. When the desired field is displayed, hold **MENU** to select it. One of the characters will flash.









1. Rotate the **Channel** knob or press the   keys to edit the desired character in the flashing position.
2. Press  to advance to the next character position.
3. Repeat steps 1 & 2 as necessary to edit the field, then hold  to save. The field will flash 3 times to confirm it has been saved.
4. If required, briefly press  to toggle between Ident and Alpha modes, then repeat steps 1 & 2 to edit the field.
5. When complete, hold  to save. The field will flash 3 times to confirm it has been saved.
6. Press  to return to the **CALL** sub-menu.
7. Press  again to return to normal operation.

Sending a SelCall from your contact list

1. Press  to enter the **CALL** Menu.
2. Rotate the **Channel** knob or press the   keys to cycle to the **SAVED** option then press  to select.
3. Press the   keys to cycle to the desired SelCall ID in your contact list.
4. With the desired contact displayed, hold the  key. The radio will transmit the SelCall Ident.

Sending a SelCall from your Recent List

The Recent List contains a list of recently received SelCalls. You can use this list to return a call or simply view who has called you.

1. Press  to enter the **CALL** Menu.
2. Rotate the **Channel** knob or press the   keys to the **RECENT** option then press  to select.
3. Press   to cycle through the **Recent** List.
4. While viewing recent callers, press  to switch between Ident mode and Alpha mode. If the selected caller is in your contact list, the Alpha Name should be viewable. If the caller is not in your contacts, only the Ident will be displayed.
5. To respond to the caller, hold the  key. The radio will transmit the selected SelCall.

Resending the last SelCall

To make another call to the last sent SelCall contact simply hold the **CALL LOCK** key. The radio will transmit the most recently sent SelCall Ident.

Manually Dialling a SelCall Ident

There may be times when you want to send a SelCall to someone without storing them in your contact list.

1. Press **CALL LOCK** to enter the **CALL** Menu.
2. Rotate the **Channel** knob or press the **▲ ▼** keys to cycle to the **DIAL** option then press **MENU P** to select.
3. The last sent or received SelCall Ident will be displayed with the right-hand digit flashing.
4. To send the displayed Ident without changes:
 - i. Hold the **CALL LOCK** key. The ident will be sent.
5. To edit the displayed Ident before sending:
 - i. Rotate the **Channel** knob or press the **▲ ▼** keys to select the desired number in the flashing digit position.
 - ii. Press **MENU P** to advance to the next digit position.
 - iii. Repeat steps i & ii to change any required digits.
 - iv. When the desired Ident is displayed, hold the **CALL LOCK** key to send.

Call acknowledge

If your SelCall transmission was successful, the radio you called should respond with a call-acknowledge transmission which will be heard in your radio as two quick beeps. This will confirm to you that the radio you called is now alerting its user to your signal. If the call-acknowledge is not received the other radio may be out of range or on a different channel.

RECEIVING A SELCALL

When someone calls your radio using SelCall, your radio will beep to alert you to the call and the Ident or Name of the caller will be displayed on the LCD. In addition, it will cancel the QUIET mode (if selected). The radio will remain in this state until you cancel the alarm.

Canceling the alarm

To cancel the alarm and clear the display, press the **MENU** key. You can now have a normal conversation on the channel. When you have finished, briefly press the **QUIET PWR** key if you wish to return to quiet operation.

If you wish to ignore the alarm and return directly to QUIET mode, briefly press the **QUIET PWR** key. The alarm will be cancelled and the channel will return to quiet operation.

Displaying the incoming SelCall contact

If the incoming SelCall is from a person in your contact list, you can choose to display either their Ident or their Name on the LCD. Displaying their name makes it much easier to identify them from other contacts.

To switch between Alpha Name or SelCall Ident:

1. Hold the **PRO DUP** key.
2. **SCALPH ON** or **SCALPH OFF** will be displayed briefly.
 - **SCALPH ON** (SelCall Alpha On) indicates the Alpha mode is on. If the incoming SelCall is in your contact list, the associated Alpha Name will be displayed.
 - **SCALPH OFF** (SelCall Alpha Off) indicates the Ident mode is on. All incoming SelCalls will display their Ident.



SelCall Alpha OFF



SelCall Alpha ON

NOTE: The SelCall Alpha/Ident toggle option described above is the default setting when holding the **PRO** key. However the **PRO** key is user programmable and can be changed. If so, the HOLD function on your **PRO** key may have a different operation. In this case follow the steps below to switch between the Alpha and Ident modes.

1. Press **CALL LOCK** to enter the **CALL** Menu.
2. Rotate the **Channel** knob or press the **▲ ▼** keys to cycle to the **SAVED** option then press **MENU F** to select.
3. While displaying a contact (it doesn't matter which one), press **MENU F** to toggle between the Ident and the Alpha Name. The option you select will determine how incoming SelCall contacts will be displayed on the LCD.
4. When finished, press **CALL LOCK** several times to exit the **CALL** menu.

NOTE: If an Alpha Name has not been programmed for the incoming contact, '-----' will be displayed.

Quiet Mode

The QUIET mode mutes the TX6600PRO's receiver to prevent any incoming signals from being heard in the speaker until your SelCall Ident is received. This allows you to monitor a busy channel for personal calls without being disturbed by unwanted signals.

If your SelCall Ident is received, the QUIET mode is cancelled and all incoming signals are heard in the speaker.

Setting up the QUIET mode

To setup the QUIET mode you must first 'tag' the channels that you want to stay Quiet. You can then activate the QUIET mode and only the channels you have tagged will remain Quiet to incoming signals (unless your SelCall Ident is received). Channels that were not tagged will remain open to all signals and will continue to operate normally.

To tag or un-tag a channel for QUIET operation

1. Rotate the **Channel** knob or press the **▲ ▼** keys to select the desired channel.
2. If the **Q** icon is visible to the right of the channel number, the channel is currently tagged for quiet operation. If the **Q** icon is not visible, the channel is not tagged.

- To tag the channel, hold the **QUIET PWR** key. **QT CH On** will be displayed briefly and the **Q** icon will appear to the right of the channel number.
- To un-tag the channel, hold the **QUIET PWR** key. **QT CH OFF** will be displayed briefly and the **Q** icon will disappear from the display.



Channel is Tagged



Channel is Un-tagged

To activate the QUIET mode

Before activating the QUIET mode you must first select a tagged channel.

- Rotate the **Channel** knob or press the **▲ ▼** keys to select a channel that has been tagged for Quiet operation. The **Q** icon will be visible on that channel.
- Briefly press the **QUIET PWR** key. The **Q** icon will change to **Q** indicating the QUIET mode is now active. All channels tagged for Quiet operation will now be operating in the QUIET Mode.

To de-activate the QUIET mode

- Select any channel that has been tagged for Quiet operation. **Q** will be visible.
- Briefly press the **QUIET PWR** key. **Q** will change to **Q** and all channels tagged for Quiet operation will now be open to all incoming signals.



Receiving signals in the QUIET mode

- If a signal is received on a QUIET channel, the channel will appear busy (the **|||** icon will be visible) but no sound will be heard from the speaker.

- If a signal is received on an Open channel (one that is not tagged with **Q**) the signal will be heard in the usual way.



If a signal containing your SelCall Ident is received on any channel – Open or QUIET – the QUIET mode will be cancelled, and the alarm will beep to alert you to the call. In addition, the caller's Ident or Alpha Name will be displayed. All channels will now be open for normal transmission and reception.

SCANNING IN QUIET MODE

Scanning while in the QUIET mode allows you to monitor a group of Quiet channels or a combination of Quiet and Open channels.

NOTE: For Open and Group Scanning only. Your radio cannot receive SelCalls while using Network Scan.

To scan in the QUIET mode

1. Press **MENU** then **SCAN** to select the desired Scan group (**OPEN1**, **OPEN2** or **GROUP** only).
2. Ensure the channels you wish to scan are stored in the selected scan memory. The  icon should be visible on those channels.
3. From these channels, select the ones you wish to remain Quiet and hold the **QUIET** key to tag them for **QUIET** operation (**Q** is displayed).
4. Press the **SCAN** key. The radio will begin scanning and the  icon will animate.
5. Now, briefly press the **QUIET** key to activate the **QUIET** mode. The  icon will appear to confirm the radio is scanning in the QUIET mode.

Receiving signals while scanning in the QUIET mode

If a signal is received on an open channel, the scan will pause while the channel is busy to allow you to hear the signal and will resume after the channel becomes clear. If you are scanning in Group Scan mode, the radio may switch between the open channel and the Priority Channel – this is normal.

If a signal is received on a Quiet channel but your SelCall Ident is not detected, the signal will be ignored and scanning will continue.

If a signal containing your SelCall Ident is received on any channel (either Open or Quiet), the scan and QUIET modes will be cancelled and the receiver will stay on the busy channel. The alarm will then beep to alert you to the call and the caller's Ident or Alpha Name will be displayed. The channel will now be open for normal communications.

TIP: To ensure reliable SelCall detection when scanning in the Open Scan mode, it is recommended that you restrict the number of channels in the Scan group to less than 20.

GROUP CALLING

The SelCall system includes a Group Call function that allows you to call up to 10 radios simultaneously. This can be useful where you need to transmit a message to several radios in your group. To achieve this, the radios you are calling must be programmed with SelCall Idents where the first 4 digits are the same on each radio.

e.g. 12340, 12341, 12342, 12343, --> 12349

The Group Call function works by inserting a special 'group code' in the last digit position of the SelCall Ident you are sending. The 'group code' appears as an 'A' when displayed in the radio. When the Group Ident is received, the 'A' substitutes for all other numbers in the last digit position, so, if the first 4 digits of the SelCall match those of the radios you are calling, each radio will respond as if all 5 digits were received

e.g.

A call to Ident 12341 will normally only activate the alarm in the radio with SelCall Ident 12341 whereas sending a group call to Ident 1234A will activate all radios with Idents 12340 through to 12349.

If the radios in your fleet do not have Selcall Idents where the first 4 digits are the same, you can reprogram them yourself as described earlier in this manual.

Programming and sending Group calls

The process for dialling or saving a Group call Ident is identical to that for a normal SelCall Ident. Simply select an 'A' in the right-hand digit position.

Call acknowledge in Group mode

There is no call acknowledge after sending a group call. This is to prevent all the radios in your call group from trying to respond at the same time.

Receiving Group calls

Receiving a Group call is identical to receiving a normal SelCall except that the alarm sound is a double beep instead of the normal single beep. The caller's Ident or Alpha Name appears on the display in the usual way.

CONSERVING YOUR BATTERY POWER

The TX6600PRO has built in power saving features to help you get the maximum amount of time between charges from your Li-ion battery pack. If you need to operate your TX6600PRO in a situation where you require maximum battery life (e.g. a remote site where there is no convenient recharging facility nearby), the following hints can greatly reduce the amount of power drawn from the battery pack.

Low Transmit Power setting

The transmitter has High, Low and Ultra-Low power settings. If you are only operating over short distances, are in a reasonably high location or are close to a local repeater, try using the Low or Ultra-Low transmit power settings. These reduce the transmitter power from a High power of 5 Watts down to 1 Watt for the Low setting and 100mW for the Ultra-Low setting, significantly extending the available 'talk' time.

Power Save mode

The Power Save function is designed to conserve power and extend the battery life by allowing the radio will sleep during periods of inactivity. The LO Power Save setting will respond more quickly to incoming signals while the HI Power Save setting will conserve the most amount of power but may not be as responsive to incoming signals. The TX6600PRO will automatically enter the Power Save mode after around 5 seconds of inactivity (i.e. no transmission or reception). As soon as a signal is received or any keys are pressed, the TX6600PRO will wake up again. This sleep function is automatic and by itself can greatly extend the battery life in standby mode by many hours.

Backlight

Turning the LCD backlight off will conserve the most amount of power or using the Auto setting for LCD backlight will turn it off after a few seconds of inactivity.

Quiet mode

If QUIET mode is selected, the TX6600PRO will remain 'muted' on Quiet channels even if they are busy unless your SelCall Ident is received.

Scanning

The TX6600PRO draws more power from the battery when scanning than when monitoring a single channel. This is because it must wake more often to monitor each channel for activity. Battery life can be extended by avoiding any unnecessary scanning. In addition, scanning several channels increases the chance of finding a signal thereby keeping the receiver awake and the Squelch open more often.









General

Continuously monitoring a busy channel will reduce the battery life because incoming signals will keep the receiver awake and the Squelch will stay open for longer periods of time. This will draw much more power from the battery pack. If you are expecting to receive a SelCall on a busy channel, program that channel for 'Quiet' operation and select the Quiet mode. The TX6600PRO will then stay 'muted' until your SelCall Ident is received.

MENU

The TX6600PRO Menu provides a convenient method of customising the radio's functions and settings.

To access the Menu:

1. Hold the  key. The last selected Menu item will be displayed.
2. Rotate the **Channel** knob or press the   keys to step through the various Menu items.
3. Press the  key to select the desired Menu item.
4. With the desired Menu item displayed, rotate the **Channel** knob or press the   keys to choose from the available selections for that item.
5. When the desired setting is displayed, press the  key to exit the menu or wait for the menu to time-out.
6. When in the menu, hold the  key to:
 - Go back one step in the menu; or
 - Enter edit mode for items where the user can enter data, (e.g. SelCall Idents or receive-only channel frequencies).

NOTE: If no keys are pressed, the menu will timeout after 10 seconds.

The following Menu options are available.

PRIVATE AND RECEIVE-ONLY CHANNELS

The TX6600PRO supports up to 119 private channels. These may be transmit channels in the frequency range 450 – 520 MHz or receive-only channels in the frequency range 403 – 520 MHz. When enabled these additional channels are located directly above CB channel 80 (81 – 199). Each private or receive-only channel can also be assigned an Alpha label to help identify that channel.

Private (transmit) channels must be programmed using the Dealer Programmer. Receive only channels can be programmed through the radio's menu.

To access the receive-only channel sub-menu

1. Hold the **MENU** key to access the menu. The last selected menu item will be displayed.
2. Rotate the **Channel** knob or press the **▲** **▼** keys until **CHAN** is displayed.
3. Press the **MENU** key to enter the **CHAN** sub-menu. **ADD** is displayed.
4. Rotate the **Channel** knob or press the **▲** **▼** keys to select one of the available sub-menu options. **ADD**, **REMOVE**, **TYPE**, **NAME**, **RXFREQ**, **TXFREQ**, **RXTONE**, **TXTONE**, **TXPWR**, **BSYLK**, or **SELCALL** will be displayed.
5. With the desired option displayed, press the **MENU** key to select it.

The following sub-menu options are included.

ADD:

- Adds a new receive-only channel. A new channel number is created above channel 80. Once you have created a new channel number you can use the **RXFREQ** option to program the frequency.
- Private channels must be added using the Dealer Programmer.

REMOVE:

- Removes (deletes) a receive only channel.
- Private channels must be removed using the Dealer Programmer.

TYPE:

- On receive-only channels - displays **RXONLY** to indicate the selected channel is a receive-only channel.
- On private channels - displays **PRIVATE** to indicate the selected channel is a private channel.
- On CB channels - displays **CB** to indicate the selected channel is a CB channel.

NAME:

- On private and receive-only channels - allows you to edit the name associated with the channel.
- On CB channels - allows you view the name associated with the channel (you cannot edit the name of a CB channel).

RXFREQ:

- On receive-only channels - allows you to edit the receive frequency.
- On CB and private channels - allows you to view the receive frequency (you cannot edit the frequency of a CB or private channel)

TXFREQ:

- On receive-only channels - displays **N/A** since there is no TX frequency.
- On CB and private channels - allows you to view the transmitter frequency (you cannot edit the frequency of a CB or private channel).

RXTONE:

- On CB and receive-only channels - displays **GLOBAL** to indicate the the main menu's CTCSS tone settings apply to all receive channels, or if the channel is not in Silent memory displays **CTCSOF** to indicate the channel does not use a subtone.
- On private channels - displays **CTCSxx/DCSxxx** to indicate that CTCSS/DCS tone in use, or **CTCSOF** to indicate the channel does not use a subtone.

TXTONE:

- On receive-only channels - displays **N/A** to indicate that transmit CTCSS tones do not apply.
- On private channels - displays **CTCSxx/DCSxxx** to indicate the CTCSS/DCS tone in use, or **CTCSOF** to indicate the channel does not use a subtone.
- On CB channels - displays **GLOBAL** to indicate that the main menu's CTCSS tone settings apply to all receive channels, or if the channel is not in Silent memory displays **CTCSOF** to indicate the channel does not use a subtone.

TXPWR:

- On receive-only channels - displays **N/A** since there are no transmissions.
- On CB and private channels - allows you to view the transmitter power setting.

BSYLK:

- On receive-only channels - displays **OFF** since there are no transmissions on the channel.
- On private channels - displays **ON** or **OFF** to indicate whether Busy Lockout is active on the channel.
- On CB channels - displays **GLOBAL** to indicate the Busy Lockout setting in the main menu applies to all CB channels.







SELCALL:

- On receive-only channels - displays **OFF** since SelCall is not supported on receive-only channels.
- On CB and private channels - displays **ON** or **OFF** to indicate whether the channel supports SelCall.

NOTE: SelCall is not supported on channels 61, 62 and 63 or on emergency channels 5/35.

Adding a Receive-only Channel

While in the CHAN sub-menu:

1. Rotate the **Channel** knob or press the   keys to cycle through the sub-menu until **ADD** is displayed.
2. Press  to select. The TX6600PRO will respond with **ADD?** and the next available receive-only channel number will be flashing.
3. To cancel and exit without adding a receive-only channel:
 - i. Briefly press . The selected channel number will be restored and you will exit the menu.
4. To continue adding a receive-only channel:
 - i. Rotate the **Channel** knob or press the   keys to select the desired receive-only channel number. Only empty channel numbers in the range of 81 to 199 will be displayed.
 - ii. When the desired channel number is flashing, hold  to accept. The new channel will be created and you will be returned to the **CHAN** sub-menu.

NOTE: New channels are automatically loaded with a frequency of 403.000 MHz. Once created, you will need to edit the frequency to suit your requirements.









Editing the Frequency of a Receive-only Channel

IMPORTANT: Before editing or reviewing any channel properties, check that the desired channel number is displayed.

- If you have only just created a new channel, the desired channel number should already be displayed.
- If not, you will need to exit the menu (select **EXIT** and hold the  key). You can then select the desired channel before re-entering the menu and navigating back to the **CHAN** sub-menu.





NOTE: You cannot remove (delete) a CB channel nor can you edit any of the properties of a CB channel although you can view them.

While in the CHAN sub-menu:

1. Rotate the **Channel** knob or press the   keys to cycle through the sub-menu until **RXFRQ** is displayed.
2. Press . The current receive frequency for the selected channel is displayed.
 - If the channel is a new receive-only channel, **403.000** is displayed otherwise the last entered frequency is displayed.
NOTE: 403.000 MHz is the lowest frequency you can program into the TX6600PRO.
3. Hold the  key to edit the frequency. The cursor will flash in the 10 MHz digit position.
4. Press the   keys or rotate the **Channel** knob to adjust the frequency in 10 MHz steps between 403 and 520 MHz.
5. When the desired value is displayed, press  to select. The flashing cursor will move to the 1 MHz digit position.
6. Repeat the process to adjust the frequency in the 1MHz, 100 kHz and 10 kHz positions. Note that when adjusting the 10 kHz position the frequency will change in 12.5 kHz steps.
7. When the desired frequency is displayed, hold  to save. The entire frequency will flash as it is saved. Press  to exit the menu.







Viewing the Frequency of a CB or Private Channel

While in the **CHAN** sub-menu:

1. Rotate the **Channel** knob or press the   keys to cycle through the sub-menu until **RXFRQ** is displayed.
2. Press . The receive frequency for the selected CB channel is displayed.
3. Press  to exit the menu.



Naming a Receive-only Channel

While in the **CHAN** sub-menu:

1. Rotate the **Channel** knob or press the   keys to cycle through the sub-menu until **NAME** is displayed.
2. Press . The current name for the selected channel is displayed.
If the channel is a new receive-only channel, -- -- -- -- -- is displayed to indicate a name has not been set, otherwise the last entered name is displayed.
3. Hold the  key to edit the name. The cursor will flash in the left-hand character position.
4. Press the  or  keys or rotate the **Channel** knob to select the desired character.





Available characters are:

PUNCTUATION	NUMBERS	LETTERS
- + * , _	1 2 3 4 5 6 7 8 9 0	A B C D E F G H I J K L M N O P Q R S T U V W X Y Z

5. When the desired character is displayed, press  to select. The flashing cursor will move to the next character position.
6. Repeat the process to enter up to 6 characters for the desired name.
7. When the desired name is displayed, hold  to save. The name will flash as it is saved. Press  to exit the menu.

Viewing the Name of a CB or Private Channel





While in the **CHAN** sub-menu:

1. Rotate the **Channel** knob or press the   keys to cycle through the sub-menu until **NAME** is displayed.
2. Press . The name assigned to the selected CB channel is displayed.
3. Press  to exit the menu.

Removing a Receive-only Channel





IMPORTANT: Before continuing, check that the correct receive-only channel number is displayed to ensure you do not remove the wrong channel.

While in the **CHAN** sub-menu:

1. Rotate the **Channel** knob or press the   keys to cycle through the sub-menu until **REMOVE** is displayed.
2. Press . **DEL?** is displayed.
 - i. To cancel without removing the channel, press . The radio will exit the menu.
 - ii. To continue removing the channel, hold . The channel number will flash then disappear as it is removed. The radio will return to the **CHAN** sub-menu.





Viewing the Channel Type

While in the **CHAN** sub-menu:

1. Rotate the **Channel** knob or press the   keys to cycle through the sub-menu until **TYPE** is displayed.
2. Press . The selected channel 'Type' is displayed.
 - i. If the channel is a CB channel **CB** is displayed.
 - ii. If the channel is a Receive-only channel **RXONLY** is displayed.
 - iii. If the channel is a Private channel **PRIVATE** is displayed.
3. Press  to exit the menu.



Viewing the Transmit Frequency

While in the **CHAN** sub-menu:

1. Rotate the **Channel** knob or press the   keys to cycle through the sub-menu until **TXFRQ** is displayed.
2. Press 
 - i. If the channel is a CB channel, the transmitter frequency for the selected channel is displayed.
 - ii. If the channel is a Receive-only channel, **N/A** is displayed.
3. Press  to exit the menu.



Viewing the Receiver CTCSS/DCS Tone Frequency

While in the **CHAN** sub-menu:

1. Rotate the **Channel** knob or press the keys to cycle through the sub-menu until **RXTONE** is displayed.
2. Press 
 - i. If the channel is a CB or Receive-only channel and no tone is enabled under CTCSS/DCS in the main menu, **CTCSOF** is displayed. Otherwise, **GLOBAL** is displayed to indicate the channel is using the CTCSS/DCS tone defined under CTCSS/DCS in the main menu.
 - ii. If the channel is a Private channel and no tone is enabled, **CTCSOF** is displayed. Otherwise the CTCSS/DCS tone the channel is using is displayed as **CTCSxx** or **DCSxxx**.
3. Press  to exit the menu.

Viewing the Transmitter CTCSS/DCS Tone Frequency





While in the **CHAN** sub-menu:

1. Rotate the **Channel** knob or press the   keys to cycle through the sub-menu until **TXTONE** is displayed.
2. Press 
 - i. If the channel is a CB or Receive-only channel and no tone is enabled under CTCSS/DCS in the main menu, **CTCSOF** is displayed. Otherwise, **GLOBAL** is displayed to indicate the channel is using the CTCSS/DCS tone defined under CTCSS/DCS in the main menu.

- ii. If the channel is a Private channel and no tone is enabled, **CTSCOF** is displayed. Otherwise the CTCSS/DCS tone the channel is using is displayed as **CTCSxx** or **DCSxxx**.
3. Press  to exit the menu.





Viewing the Transmitter Power Setting

While in the **CHAN** sub-menu:

1. Rotate the **Channel** knob or press the   keys to cycle through the sub-menu until **TXPWR** is displayed.
2. Press .
- i. If the channel is a CB or Private channel, the transmitter power setting for the selected channel is displayed as **5W**, **1W** or **100MW**.
 - ii. If the channel is a Receive-only channel **N/A** is displayed.
3. Press  to exit the menu.





Viewing the Busy Lockout Setting

While in the **CHAN** sub-menu:

1. Rotate the **Channel** knob or press the   keys to cycle through the sub-menu until **BSYLK** is displayed.
2. Press .
- i. If the channel is a CB channel, **GLOBAL** is displayed to indicate it is following the Busy Lockout setting in the main menu.
 - ii. If the channel is a Private channel, **ON**, **OFF** or **GLOBAL** is displayed to indicate whether Busy Lockout is enabled or is configured to follow the user configurable global setting.
 - iii. If the channel is a Receive-only channel, **OFF** is displayed since the radio is unable to transmit on a Receive-only channel.
3. Press  to exit the menu.

Viewing the SelCall Setting

While in the **CHAN** sub-menu:

1. Rotate the **Channel** knob or press the   keys to cycle through the sub-menu until **SELCALL** is displayed.
2. Press 
 - i. **ON** will be displayed if a CB or Private channel is configured to receive and respond to SelCalls.
 - ii. **OFF** will be displayed if the channel is a Receive-only channel or is configured to not receive or respond to SelCalls.
3. Press  to exit the menu.

Displaying Alpha Names on Receive-only channels

When a name is applied to a Receive-only or Private channel, the menu's display (**dSP**) setting is automatically set to display the name (**CHNAME**) under the channel number whenever a receive-only or Private channel is selected. This setting is separate to the menu's display setting for CB channels. i.e. you can have the channel name displayed on receive-only and Private channels and still have the signal meter displayed on CB channels.



If a name has not been applied to any Receive-only or Private channels the radio will default to displaying the Signal meter (S-MET) setting.

You can use the menu to manually change the display setting on Receive-only and Private channels at any time.

The default display setting may also be configured from the dealer software.

Scanning on a Receive-only Channel

Receive-only and Private channels can be programmed into your Open or Group scan groups in the same way as your normal CB channels. Receive-only channels cannot be programmed into your Network Scan group.

To add a Receive-only or Private channel to your scan group, simply select the required scan group (Open1, Open2 or Group), select the Receive-only or Private channel then press and hold the  key until the radio beeps.  will be displayed on that channel. For more details on scanning, see the section on 'Scanning' in this manual.

PROGRAMMABLE KEYS

The TX6600PRO has 6 programmable keys that can be configured as shortcuts to frequently used features. The keys are programmed using the Dealer Programmer. The following diagram shows the keys that are available for programming.

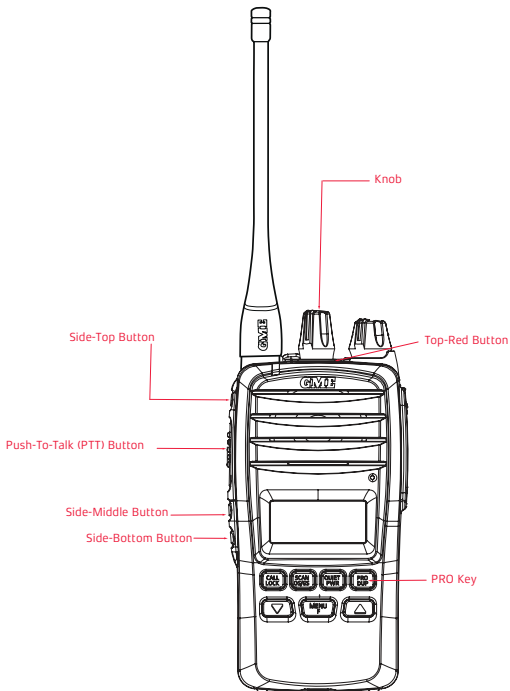

The PRO key can be programmed with 2 separate features, either through the radio menu or the Dealer Programmer. All other keys can be programmed with up to three separate features through the Dealer Programmer.

Primary function: Press the key.

Secondary function: Press & hold the key.

Third function: Press **F** then press the key.



The following programmable key functions are available to be programmed into your radio. If so, some keys will directly cycle the available setting while others will allow adjustments through a menu. Please read the user manual for detailed operational descriptions of each of these features.

Backlight Cycle

Press the programmed **Backlight** key to cycle **ON**, **OFF** or **AUT**.

- **ON**: The backlight is always On.
- **OFF**: The backlight is always Off.
- **AUT**: The backlight will switch on when a key is pressed but will switch off automatically after 5 seconds.

Backlight Menu

1. Press the programmed **Backlight Menu** key to access the backlight menu.
2. Rotate the **Channel** knob or press the   keys to select **ON**, **OFF** or **AUT**.
 - **ON**: The backlight is always On.
 - **OFF**: The backlight is always Off.
 - **AUT**: The backlight will switch on when a key is pressed but will switch off automatically after 5 seconds.
3. Press the  key to exit or wait a few seconds for the menu to time-out.

Battery Voltage

1. Press the programmed **Battery Voltage** key to temporarily display the battery voltage in the area below the channel display.
2. Press any key to return to the normal display.

Beep Cycle

Press the programmed **Beep** key to cycle **ON**, **OFF** or **ALT**.

- **ON**: The radio will beep whenever a key is pressed or when an alert is required.
- **OFF**: All Beeps are inhibited
- **ALT**: The radio will only beep when an alert is required. Key beeps are inhibited.

Beep Menu

1. Press the programmed **Beep Menu** key to access the Beep menu.
2. Rotate the **Channel** knob or press the keys to select **ON**, **OFF** or **ALT**.
 - **ON**: The radio will beep whenever a key is pressed or when an alert is required.
 - **OFF**: All Beeps are inhibited
 - **ALT**: The radio will only beep when an alert is required. Key beeps are inhibited.
3. Press the  key to exit or wait a few seconds for the menu to time-out.



CB PTT ANI Toggle

Press the programmed **CB PTT ANI Toggle** key to toggle PTT triggered SelCall ANI transmission on CB channels **ON** or **OFF**. The setting Enable PTT ANI on CB Channels must be enabled in the dealer programmer.

Channel Announce Toggle

Press the programmed **Channel Announce Toggle** key to toggle the Channel Announce setting **ON** or **OFF**.

Channel Announce Menu

1. Press the programmed **Channel Announce Menu** key to access the Channel Announce menu.
2. Rotate the **Channel** knob or press the   keys to switch the Channel Announce setting **ON** or **OFF**.
3. Press the  key to exit or wait a few seconds for the menu to time-out.

Channel Menu

1. Press the **Channel Menu** key to enter the Receive-only Channel Editing menu. Here you can edit receive-only channels or view the details of CB and Private channels.
2. Rotate the **Channel** knob or the keys to navigate the Channel menu options.
3. Press  to select an option.

For full Channel Menu editing instructions, please see the Private and Receive-only Channels section of this User Manual.

Duplex Toggle

1. Select the desired repeater channel (CB1-8, CB31-38 or a duplex private channel).
2. Press the programmed **Duplex Toggle** key to toggle Duplex **ON** or **OFF** on the selected channel. The  icon indicates when Duplex is On.

NOTE: Duplex cannot be enabled on Simplex channels.

Duplex Menu

1. Select the desired repeater channel (CB1-8, CB31-38 or a duplex private channel).
2. Press the programmed **Duplex Menu** key to access the Duplex menu.
3. Rotate the **Channel** knob or press the keys to select Duplex **ON** or **OFF** on the selected channel. The icon indicates when Duplex is On.
NOTE: Duplex cannot be enabled on Simplex channels.
4. Press the  key to exit or wait a few seconds for the menu to time-out.

Dynamic Volume Control Toggle

Press the programmed **Dynamic Volume Control Toggle** key to toggle the Dynamic Volume Control **ON** or **OFF**.

Dynamic Volume Control Menu

1. Press the programmed **Dynamic Volume Control Menu** key to access the Dynamic Volume Control menu.
2. Rotate the **Channel** knob or press the keys to select **ON** or **OFF**.
3. Press the  key to exit or wait a few seconds for the menu to time-out.

Emergency

Press the programmed **Emergency** key to immediately send a designated Emergency SelCall transmission to other radios in your group. During this time your radio will sound an alarm and display EMERGENCY. The emergency SelCall transmissions will continue until cancelled by the **Exit Emergency** key.

Other radios in your group that receive the Emergency signal will also sound an alarm and ALARM will be displayed on the LCD.

Exit Emergency

Press the programmed **Exit Emergency** key to cancel the Emergency. The Emergency SelCall transmissions will cease and the alarm will stop.

Keylock Toggle

Press the programmed **Keylock** key to toggle the Keylock function **ON** or **OFF**. **LOCKED** or **UNLOCK** will be displayed briefly to confirm the status of the keylock function.

LCD TEST MODE (Maintenance option for testing the LCD display)

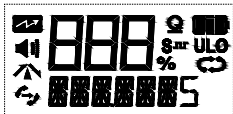

Press the programmed **LCD Test Mode** key to activate every segment and icon on the display. The display will return to normal after a short time.

MODULATION TEST (Maintenance option for testing the transmitter modulation)

NOTE: Pressing the **Modulation Test** key will cause the radio to begin transmitting. Please ensure the selected channel is clear **BEFORE** starting this test.

1. Press the programmed **Modulation Test** key. The radio will begin transmitting a 1000Hz tone and the Red Status LED will light.
2. While transmitting, rotate the **Channel** knob or press the **▲ ▼** keys to change the tone frequency in 100Hz steps.
3. Press the programmed **Modulation Test** key again to stop the test. The Red Status LED will extinguish.

Monitor Toggle

Press the programmed **Monitor Toggle** key to toggle the Monitor function **ON** or **OFF**.

Monitor Menu

1. Press the programmed **Monitor Menu** key to access the Monitor menu.
2. Rotate the **Channel** knob or press the keys to select **ON** or **OFF**.
3. Press the **MENU** key to exit or wait a few seconds for the menu to time-out.

Audio Amplifier Test: (Maintenance option for testing the receiver audio power amplifier)



1. Press the programmed **Audio Amplifier Test** key to generate a 1000Hz tone in the speaker.
2. Rotate the **Channel** knob or press the keys to change the tone frequency in 100Hz steps.
3. Press the programmed **Audio Amplifier Test** key again to stop the test.

Power Saving Cycle

Press the programmed **Power Saving** key to cycle **OFF**, **LO** or **HI**.

- Select **OFF** to switch the Power Save function Off. The radio will remain active at all times and will draw the most amount of power from the battery.
- Select **LO** to enable the Power Save function at a conservative setting. The radio will sleep during periods of inactivity but will respond quickly to incoming signals.
- Select **HI** to enable the Power Save function at a more aggressive setting. The radio will conserve the most amount of power but may not be as responsive to incoming signals.

Power Saving Menu

1. Press the programmed **Power Saving Menu** key to access the Power Saving menu.
2. Rotate the **Channel** knob or press the   keys to select **OFF**, **LO** or **HI**.
 - Select **OFF** to switch the Power Save function Off. The radio will remain active at all times and will draw the most amount of power from the battery.
 - Select **LO** to enable the Power Save function at a conservative setting. The radio will sleep during periods of inactivity but will respond quickly to incoming signals.
 - Select **HI** to enable the Power Save function at a more aggressive setting. The radio will conserve the most amount of power but may not be as responsive to incoming signals.
3. Press the  key to exit or wait a few seconds for the menu to time-out.

Set PRI



Press the programmed **Set PRI** key to save the currently selected channel to the designated priority channel memory (priority channel 1 or 2). This channel can then be instantly recalled using the programmed **PRI** key.

PRI

Press the programmed **PRI** key to switch immediately to the designated priority channel (priority channel 1 or 2). This channel may be preset using the dealer software or saved using the Set **PRI** key (above).

Dual Watch



1. Choose your selected channel using the **Channel** knob or the   keys.
2. Press the programmed Dual Watch key to activate **Dual Watch**.
3. **DW - xx** is displayed (where **xx** is your last selected priority channel) and the icon will animate. The radio is now watching both the selected channel and the last selected priority channel.

NOTE: If the selected channel and the priority channel are the same, Dual Watch will not start and **SCAN ERROR** will be displayed. In this case please select another channel.

To Exit Dual Watch

Press the programmed **Dual Watch** key. Dual watch will stop and the radio will return to normal operation.

Triple Watch

Triple Watch scans the selected channel, Priority Channel 1 and Priority Channel 2.



1. Choose your selected channel using the **Channel** knob or the keys.
2. Press the programmed **Triple Watch** key to activate Triple Watch.
3. **TW - xx** will appear (where **xx** will alternate between your two priority channels) and the  icon will animate. The radio is now watching all three channels.

NOTE: If the selected channel and either of the priority channels are the same, Triple Watch will not start and **SCAN ERROR** will be displayed. In this case please select another channel.

To Exit Triple Watch

Press the programmed **Triple Watch** key. Triple Watch will stop and the radio will return to normal operation.

Quiet Channel Toggle

Press the programmed **Quiet Channel Toggle** key to toggle the quiet mode **ON** or **OFF** on the selected channel. This will TAG or UNTAG the selected channel for Quiet SelCall operation.

- Select **ON** to tag the selected channel. **Q** is displayed on the selected channel
- Select **OFF** to un-tag the selected channel. **Q** disappears from the selected channel.



Channel is tagged



Channel is Un-tagged

Quiet Channel Menu

1. Press the programmed **Quiet Channel Menu** key to access the Quiet Channel menu.
2. Rotate the **Channel** knob or press the **▲** **▼** keys to tag or untag the selected channel for Quiet SelCall operation.
 - Select **ON** to tag the selected channel. **Q** is displayed on the selected channel
 - Select **OFF** to un-tag the selected channel. **Q** disappears from the selected channel.
3. Press the **MENU** key to exit or wait a few seconds for the menu to time-out.

Quiet

1. Select a channel that has been tagged for SelCall Quiet operation. **Q** will be visible on that channel.
2. Press the programmed Quiet key to enable or disable the QUIET mode.
 - Select **ON** to enable the QUIET mode. changes to on the selected channel
 - Select **OFF** to disable the QUIET mode. **Q** changes to **Q** on the selected channel.



Set Channel To Key

Saves the selected channel and assigns it to a prespecified **Recall Channel** key.

1. Select the desired channel.
2. Press the programmed **Set Channel To Key** key. The selected channel will be saved and assigned to a designated **Recall Channel** key.

NOTE: The specified **Recall Channel** key must also have been defined by the dealer software.

To recall the channel, use the assigned **Recall Channel** key (as described below)

Recall Channel

Press the programmed **Recall Channel** key to immediately recall to a preset channel. The recall channel may have been saved using the **Set Channel To Key** option above or may have been preset by the dealer software.

Dial Selcall

Press the programmed **Dial SelCall** key to immediately make a SelCall to a predefined SelCall contact on the selected channel. The SelCall contact is predefined using the dealer software.

Recall/Dial Selcall

Press the programmed **Recall/Dial SelCall** key to switch to a predefined channel and transmit a SelCall to a predefined SelCall contact. The radio will stay on the channel to listen for a response. The channel and the SelCall contact are predefined using the dealer software.

Redial Selcall

Press the programmed **Redial SelCall** key to automatically resend the last-sent SelCall Ident on the selected channel.



Roger Beep Toggle

Press the programmed **Roger Beep Toggle** key to toggle the Roger Beep function **ON** or **OFF**.

- Select **ON** to enable the Roger Beep feature.
- Select **OFF** to disable the Roger Beep feature.

When Roger Beep is **ON** a two-tone beep will be heard by the receiving station at the end of your transmission to indicate that it is their turn to speak.

Roger Beep Menu

1. Press the programmed **Roger Beep Menu** key to access the Roger Beep menu.
2. Rotate the **Channel** knob or press the   keys to switch the Roger Beep function **ON** or **OFF**.
 - Select **ON** to enable the Roger Beep feature.
 - Select **OFF** to disable the Roger Beep feature.
3. Press the  key to exit or wait a few seconds for the menu to time-out.

RSSI

1. Press the programmed **RSSI** key to temporarily display the incoming signal strength in dBm in the area below the channel display.
2. Press any key to return to the normal display.

Scan

1. Press the programmed **Scan** key to start the Scan function.
2. While scanning, press the programmed **Scan** key again to stop the Scan function. The radio will return to normal operation.

For more details on scanning, please refer the section on Scanning in the User Manual.

Scan Hold

Press the programmed **Scan Hold** key while scanning has paused on a busy channel to stay on the channel.

Scan Resume

Press the pre-programmed **Scan Resume** key while paused on a busy channel to resume scanning.

This function can also be duplicated by rotating the **Channel** knob or pressing  .

Scan Remove

Press the programmed Scan Remove key while scanning has paused on a busy channel to remove the channel from the scan.

Scan Group

Press the programmed **Scan Group** key to cycle through the available scan groups. By default each key press will cycle through **OPEN1**, **OPEN2**, **GROUP** or **NETWK**. This is the same as pressing the **F** and **OS/GS** keys.

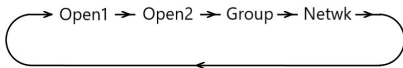

NOTE: NETWK will not appear unless NETWORK SCAN has been enabled in the menu

Scrambler Toggle

Press the programmed **Scrambler** key to toggle the Scrambler **ON** or **OFF**.

NOTE: The scrambler cannot be enabled on CB channels where Duplex is selected or on CB repeater output channels (31-38 or 71-78).

Silent On

Silent ON enables the Silent mode to allow CTCSS/DCS control of your selected channel. When enabled, your radio remains quiet to all incoming signals except those that are using the same CTCSS or DCS code as your radio.

1. Select a channel.
2. Press the programmed **Silent ON** key to enable Silent mode on that channel. The **S** (CTCSS) or **S_{PL}** (DCS) icon will be displayed on that channel.
3. Repeat steps 1 & 2 to enable Silent mode on other channels.

NOTE: Before enabling Silent mode you need to select a suitable CTCSS or DCS tone.

Silent Off

Silent OFF disables the Silent mode which removes CTCSS/DCS control of your selected channel allowing you to hear all incoming signals.

1. Select a channel.
2. Press the programmed **Silent OFF** key to disable Silent Mode on that channel. The **S** (CTCSS) or **S_{PL}** (DCS) icon will no longer appear on that channel.
3. Repeat steps 1 & 2 to select Silent OFF on other channels.

Silent Channel Toggle

Switches the Silent mode ON or OFF. When Silent mode is ON, your selected channel will be under the control of a CTCSS/DCS tone and will remain quiet to all incoming signals except those that are using the same CTCSS or DCS code as your radio. When Silent mode is OFF you will be able to hear all incoming signals on the selected channel.

1. Select a channel.
2. Press the programmed **Silent Channel Toggle** key to toggle the Silent Mode **ON** or **OFF** on the selected channel.

When Silent Mode is ON, the **S** (CTCSS) or **S_{nr}** (DCS) icon will appear on the selected channel. When Silent Mode is OFF, the **S** (CTCSS) or **S_{nr}** (DCS) icon will disappear from the selected channel.

NOTE: Before enabling Silent mode you need to select a suitable CTCSS or DCS tone.

Subtone

To select a CTCSS or DCS tone

1. Press the programmed **Subtone** key to access the CTCSS/DCS menu.
2. Rotate the **Channel** knob or press the **▲** **▼** key to enable CTCSS or DCS and select a suitable tone.
 - Rotate the **Channel** knob clockwise or press the **▲** key to select CTCSS tones 01 to 50.
 - Rotate the **Channel** knob counter-clockwise or press the **▼** key to select DCS tones 001 to 104.
 - To disable CTCSS or DCS, select **OFF**
3. Press the **MENU** key to exit or wait a few seconds for the menu to time-out.



CTCSS/DCS is OFF





CTCSS Tone 05 Selected





DCS Code 103 Selected

Selcall Menu

1. Press the programmed **SelCall Menu** key to access your SelCall Contact list.
2. Rotate the **Channel** knob or press the   keys to select from the available SelCall contacts (or select **FREE** to add a new contact - see the SelCall section of the User Manual for details)
3. Hold the **CALL** key to send the SelCall.

Selcall Alpha Select

View a SelCall contact as either a numeric Ident or an alpha name.

1. Press the programmed SelCall Alpha Select key to access the SelCall Alpha Selection Menu.
2. Rotate the **Channel** knob or press the   keys to switch the SelCall Alpha setting **ON** or **OFF**.

SCALPH ON or **SCALPH OFF** will be displayed.

- **SCALPH ON:** The SelCall contact's alpha name will be displayed.
 - **SCALPH OFF:** The SelCall contact's numeric Ident will be displayed.
3. Press the  key to exit or wait a few seconds for the menu to time-out.

Selcall Alpha Toggle

View a SelCall contact as either a numeric Ident or an alpha name.

Press the programmed SelCall Alpha Toggle key to switch the SelCall Alpha setting **ON** or **OFF**.

SCALPH ON or **SCALPH OFF** will be displayed.

- **SCALPH ON:** The SelCall contact's alpha name will be displayed.
- **SCALPH OFF:** The SelCall contact's numeric Ident will be displayed.

Silent Squelch Tail (SST) Toggle

The Silent Squelch Tail function removes the short burst of noise that is heard in the speaker just before the Squelch closes at the end of a transmission.

Press the programmed **Silent Squelch Tail Toggle** key to toggle the Silent Squelch Tail function **ON** or **OFF**.

SST ON or **SST OFF** will be displayed.

Silent Squelch Tail (SST) Menu

The Silent Squelch Tail function removes the short burst of noise that is heard in the speaker just before the Squelch closes at the end of a transmission.

1. Press the programmed **Silent Squelch Tail Menu** key to access the Silent Squelch Tail menu.
2. Rotate the **Channel** knob or press the keys to switch the Silent Squelch Tail setting **ON** or **OFF**. **SST ON** or **SST OFF** will be displayed.
3. Press the  key to exit or wait a few seconds for the menu to time-out.

Squelch Toggle

Press the programmed **Squelch Toggle** key to toggle the squelch Open or Closed.



- When the squelch is open, **SQLCH OPn** will appear briefly and the receiver noise will be heard in the speaker.
- When the squelch is closed, **SQLCH CLS** will appear briefly and the receiver will remain quiet.

Squelch Menu

1. Press the programmed **Squelch Menu** key to enter the Squelch menu.
2. Rotate the **Channel** knob or press the keys to Open or Close the Squelch.
 - When the squelch is open, **SQLCH OPn** will appear and the receiver noise will be heard in the speaker.
 - When the squelch is closed, **SQLCH CLS** will appear and the receiver will remain quiet.
3. Press the  key to exit or wait a few seconds for the menu to time-out.

Squelch Level

The Squelch level sets the sensitivity of the Squelch to incoming signals.

1. Press the programmed **Squelch Level** key to enter the Squelch Level menu.
2. Rotate the **Channel** knob or press the   key to adjust the Squelch level from a minimum of 1 to a maximum of 9.
3. Press the  key to exit or wait a few seconds for the menu to time-out.

Status Message Toggle

Press the programmed **Status Message Toggle** key to enter to toggle Status Messages **ON** or **OFF**.

MSGTXT ON or **MSGTXT OFF** will be displayed.

Status Message Menu

1. Press the programmed **Status Message Menu** key to enter the Status Messages menu.
2. Rotate the **Channel** knob or press the **▲ ▼** key to toggle Status Messages **ON** or **OFF**.

MSGTXT ON or **MSGTXT OFF** will be displayed.

3. Press the **MENU** key to exit or wait a few seconds for the menu to time-out.

Status Messages ON

Press the programmed **Status Messages On** key to switch Status Messages **ON**.

MSGTXT ON will appear briefly.

Status Messages OFF

Press the programmed **Status Messages Off** key to switch Status Messages **OFF**.

MSGTXT OFF will appear briefly.

TX Power Cycle

Press the programmed **TX Power Cycle** key to cycle the transmitter power setting. At each key press the radio will display **5W**, **1W** or **100mW**.

When 5W is selected the radio will transmit at maximum power. When 1W is selected the **LO** icon is displayed. When 100mW is selected the **ULO** icon is displayed.

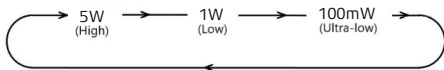

TX Power Menu

1. Press the programmed **TX Power Menu** key to access the Transmitter Power setting menu. The radio will display **5W**, **1W** or **100mW**.
2. Rotate the **Channel** knob or press the **▲ ▼** key to cycle the Transmitter Power. The radio will display **5W**, **1W** or **100mW**.
3. Press the **MENU** key to exit or wait a few seconds for the menu to time-out.

MENU OPTIONS

Display	Function	Sub Menu	Settings	Default
SQLCH	Squelch Level		1 - 9	3
SUBTONE	CTCSS & DCS		OFF, CTCSS 1-50, DCS 001-104	OFF
NETSCN	Netscan		OFF, CTCSS 1-50, DCS 001-104	OFF
SCRAMB	Scrambler		ON, OFF	OFF
SQLTAIL	Silent Squelch Tail		ON, OFF	ON
BUSYLK	Busy Lockout		ON, OFF	OFF
RGBEEP	Roger Beep		ON, OFF	OFF
PWRSVAV	Power Save		OFF, LO, HI	OFF
BACKLT	Backlight		AUT, ON, OFF	AUT
BEEP	Beep		ALT, ON, OFF	ON
CH ANN	Channel Announce		ON, OFF	ON
DYNVOL	Dynamic Volume Control		ON, OFF	ON
MIC G	Microphone Gain		0 - 9	0
NBFILT	Narrow Band Filter		ON, OFF	ON
PROKEY	PRO Key		DW/TW, SQLLVL, DISP, RECALL, PWRSVAV, BEEP	DISP
DISPLAY	Display		S-MET, S-LIN, BATT V, CHNAME, RXFREQ, TXFREQ, FREQ, IDNAME, ID NO, OFF	S-MET
MSGTXT	Message Text		ON, OFF	ON
CB PTT ANI	PTT ANI on CB Channels		ON, OFF	OFF
INFO	Information	MODEL SERNO OWNID FWVER HWVER	Displays Model Name. Displays Serial Number Displays Own SelCall Ident Displays Firmware Version Displays Hardware Version	
CHAN	Channel	ADD REMOVE TYPE NAME RXFRQ TXFRQ RXTONE TXTONE TXPWR BSYLK SELCALL	Adds an RX-only Channel Removes an RX-only Channel Specify Type of Channel Name an RX-only Channel View the name of a CB Channel Receive Frequency Transmit Frequency Receive Tone Transmit Tone Transmit Power Busy Lockout SelCall	

MENU OPTIONS

Display	Function	Sub Menu	Settings	Default
DIAG	Diagnostics	RSSI LCD TEST TX TEST AUDIO TEST BATTERY	Displays Signal Strength Turns On All LCD Segments Transmits a Tone Plays a Tone on the Speaker Displays Battery Voltage	
RESET	Reset		Factory Reset	

CTCSS TONE FREQUENCIES

No.	Frequency	No.	Frequency	No.	Frequency	No.	Frequency
1	67.0	14	107.2	27	167.9	40	159.8
2	71.9	15	110.9	28	173.8	41	165.5
3	74.4	16	114.8	29	179.9	42	171.3
4	77.0	17	118.8	30	186.2	43	177.3
5	79.7	18	123.0	31	192.8	44	183.5
6	82.5	19	127.3	32	203.5	45	189.9
7	85.4	20	131.8	33	210.7	46	196.6
8	88.5	21	136.5	34	218.1	47	199.5
9	91.5	22	141.3	35	225.7	48	206.5
10	94.8	23	146.2	36	233.6	49	229.1
11	97.4	24	151.4	37	241.8	50	254.1
12	100.0	25	156.7	38	250.3	-	-
13	103.5	26	162.2	39	269.4	-	-

DCS CODES

DCS CODES											
DCS	CODE	DCS	CODE	DCS	CODE	DCS	CODE	DCS	CODE	DCS	CODE
1	023	19	116	37	225	55	325	73	452	91	627
2	025	20	122	38	226	56	331	74	454	92	631
3	026	21	125	39	243	57	332	75	455	93	632
4	031	22	131	40	244	58	343	76	462	94	654
5	032	23	132	41	245	59	346	77	464	95	662
6	036	24	134	42	246	60	351	78	465	96	664
7	043	25	143	43	251	61	356	79	466	97	703
8	047	26	145	44	252	62	364	80	503	98	712
9	051	27	152	45	255	63	365	81	506	99	723
10	053	28	155	46	261	64	371	82	516	100	731
11	054	29	156	47	263	65	411	83	523	101	732
12	065	30	162	48	265	66	412	84	526	102	734
13	071	31	165	49	266	67	413	85	532	103	743
14	072	32	172	50	271	68	423	86	546	104	754
15	073	33	174	51	274	69	431	87	565	-	-
16	074	34	205	52	306	70	432	88	606		
17	1 14	35	212	53	311	71	445	89	612	-	-
18	1 15	36	223	54	315	72	446	90	624	-	-

UHF CB OPERATING FREQUENCIES

CH	Frequency (MHz)	CH	Frequency (MHz)	CH	Frequency (MHz)	CH	Frequency (MHz)
1	476.425	21	476.925	41	476.4375	61	476.9375
2	476.450	22	476.950	42	476.4625	62	476.9625
3	476.475	23	476.975	43	476.4875	63	476.9875
4	476.500	24	477.000	44	476.5125	64	477.0125
5	476.525	25	477.025	45	476.5375	65	477.0375
6	476.550	26	477.050	46	476.5625	66	477.0625
7	476.575	27	477.075	47	476.5875	67	477.0875
8	476.600	28	477.100	48	476.6125	68	477.1125
9	476.625	29	477.125	49	476.6375	69	477.1375
10	476.650	30	477.150	50	476.6625	70	477.1625
11	476.675	31	477.175	51	476.6875	71	477.1875
12	476.700	32	477.200	52	476.7125	72	477.2125
13	476.725	33	477.225	53	476.7375	73	477.2375
14	476.750	34	477.250	54	476.7625	74	477.2625
15	476.775	35	477.275	55	476.7875	75	477.2875
16	476.800	36	477.300	56	476.8125	76	477.3125
17	476.825	37	477.325	57	476.8375	77	477.3375
18	476.850	38	477.350	58	476.8625	78	477.3625
19	476.875	39	477.375	59	476.8875	79	477.3875
20	476.900	40	477.400	60	476.9125	80	477.4125

	Emergency use only
	Telemetry I SelCall use only. Voice transmission is inhibited as required by AS/NZS4 365.2011
	Guard band channel. Transmission is inhibited as required by AS/NZ 4365.2011
	Repeater input channels (Duplex)
	Repeater output channels (Duplex)
11	Officially designated call channel
40	Road channel
18	Caravan and motorhome
10	4WD I Offroad

SPECIFICATIONS

GENERAL	
Compliance:	AS/NZS 4365 for radio communications equipment in the UHF citizen band and personal radio service. AS/NZS 4295 for analogue speech (angle modulated) equipment operating in the land mobile and fixed services bands in the frequency range 29.7 MHz to 1 GHz.
Frequency Range:	TX: 450 MHz – 520 MHz RX: 403 MHz – 520 MHz
Number of Channels:	199 (80 CB plus 119 private channels)
Channel Spacing:	12.5 kHz / 25 kHz
Scanning Speed:	45 channels per second (22 ms per channel)
Antenna:	50Ω, SMA male
Supply Voltage:	7.4 V DC
Battery Type:	Li-Ion
Battery Capacity:	2600 mAh
Operating Time:	18 h / 21 h / 22 h (5 W, power saving OFF / LO / HI) 24 h / 33 h / 34 h (1 W, power saving OFF / LO / HI) 30 h / 49 h / 52 h (100 mW, power saving OFF / LO / HI)

TRANSMITTER	
RF Output:	High: 5 W Low: 1 W Ultra-Low: 100 mW
Frequency Stability:	± 2.5 PPM
Modulation:	FM
Spurious Emission:	< -34 dBm
Adjacent Channel Power:	< -67 dBm
Maximum Deviation:	± 2.5 kHz
Audio Harmonic Distortion:	0.4% @ 1kHz / 1.5kHz Deviation

RECEIVER	
Sensitivity:	-120 dBm for 12 dB SINAD
Intermediate Frequencies:	1st: 38.85 MHz 2nd: 450 kHz
Adjacent Channel Selectivity:	> 60 dB (NB)
	> 70 dB (WB)
Spurious Response Immunity:	> 70 dB
Audio Output Power:	1.5 W (8Ω)
Audio Signal to Noise:	34 dB (SINAD)

MECHANICAL AND ENVIRONMENTAL	
Dimensions:	59 mm (W) x 42 mm (D) x 128 mm (H) (not including antenna)
Weight:	337 grams (with battery and antenna)
Operating Temperature:	-20° C to +60° C
Ingress Protection:	IP67 (dust tight and waterproof)
Accessory Connector:	GME 3.5 mm / 2.5 mm stereo jack
NOTE: All values are typical unless otherwise stated and are subject to change without notice or obligation.	

MIL-STD 810G		
Standard	Method	Procedure
High Temperature	501.5	i, ii
Low Temperature	502.5	i, ii
Temperature Shock	503.5	i
Rain Blowing/Drip	506.5	i, iii
Humidity	507.5	
Salt Fog	509.5	
Dust Blowing	510.5	i
Immersion	512.5	i
Vibration	514.6	i
Shock	516.6	i, iv

1. Consumer guarantees

- 1.1 Our goods come with guarantees that cannot be excluded under the Australian Consumer Law. You are entitled to a replacement or refund for a major failure and for compensation for any other reasonably foreseeable loss or damage. You are also entitled to have the goods repaired or replaced if the goods fail to be of acceptable quality and the failure does not amount to a major failure.
- 1.2 To the extent we are able, we exclude all other conditions, warranties and obligations which would otherwise be implied.

2. Warranty against defects:

- 2.1 This Warranty is in addition to and does not limit, exclude or restrict your rights under the Competition and Consumer Act 2010 (Australia) or any other mandatory protection laws that may apply.
- 2.2 We warrant our goods to be free from defects in materials and workmanship for the warranty period (see warranty table) from the date of original sale (or another period we agree to in writing). Subject to our obligations under clause 1.2, we will at our option, either repair or replace goods which we are satisfied are defective. We warrant any replacement parts for the remainder of the period of warranty for the goods into which they are incorporated.
- 2.3 To the extent permitted by law, our sole liability for breach of a condition, warranty or other obligation implied by law is limited.
 - (a) In the case of goods we supply, to any one of the following as we decide –
 - (i) The replacement of the goods or the supply of equivalent goods.
 - (ii) The repair of the goods.
 - (iii) The cost of repairing the goods or of acquiring equivalent goods.
 - (b) In the case of services we supply, to any one of the following as we decide –
 - (i) The supplying of the services again
 - (ii) The cost of having the services supplied again.

- 2.4 For repairs outside the warranty period, we warrant our repairs to be free from defects in materials and workmanship for three months from the date of the original repair. We agree to re-repair or replace (at our option) any materials or workmanship which we are satisfied are defective.
- 2.5 We warrant that we will perform services with reasonable care and skill and agree to investigate any complaint regarding our services made in good faith. If we are satisfied that the complaint is justified, and as our sole liability to you under this warranty (to the extent permitted at law), we agree to supply those services again at no extra charge to you.
- 2.6 To make a warranty claim you must before the end of the applicable warranty period (see warranty table), at your own cost, return the goods you allege are defective, provide written details of the defect, and give us an original or copy of the sales invoice or some other evidence showing details of the transaction.

Before returning any goods you will be required to follow the available options:

Contact our Customer Support Team on 1300 463 463 or techsupport@gme.net.au.

A customer support team member will troubleshoot and validate if your product is faulty. If so, they will email you a product RMA (Return Material Authorisation).

Products that are authorised to be returned to Standard Communications must include the following:

RMA form (Return Material Authorisation)

A copy of your proof of purchase, the faulty product, including all accessories

- 2.7 Send your claim to:
GME Pty Ltd.
17 Gibbon Rd, Winston Hills, NSW 2153, Australia.
Tel: (02) 8867 6000 Fax: (02) 8867 6199.
Email: servadmin@gme.net.au
- 2.8 If we determine that your goods are defective, we will pay for the cost of returning the repaired or replaced goods to you, and reimburse you for your reasonable expenses of sending your warranty claim to us.

3. What this warranty does not cover:

- 3.1 This warranty will not apply in relation to:
- (a) Goods modified or altered in any way.
 - (b) Defects and damage caused by use with non Standard Communications products.
 - (c) Repairs performed other than by our authorised representative.
 - (d) Defects or damage resulting from misuse, accident, impact or neglect.
 - (e) Goods improperly installed or used in a manner contrary to the relevant instruction manual; or
 - (f) Goods where the serial number has been removed or made illegal.

4. Warranty period:

- 4.1 We provide the following warranty on GME and Kingray products. No repair or replacement during the warranty period will renew or extend the warranty period past the period from original date of purchase.

Product Type	Warranty Period
UHF CB Portable Radio (TX6600PRO)	5 Years
Li-ion Battery Packs	1 Year



PROFESSIONAL

gme.net.au

GME Pty Ltd
17 Gibbon Road, Winston Hills NSW 2153, Australia
Drawing Number: 51902-1